

REV
SH
SR1LW6-SM
DWG NO

REVISIONS			
REV	DESCRIPTION	DATE	APPROVED

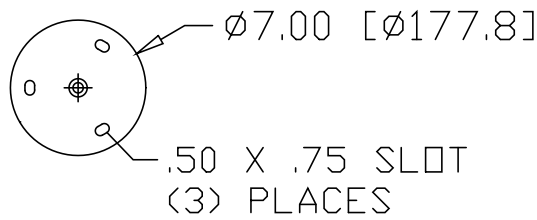
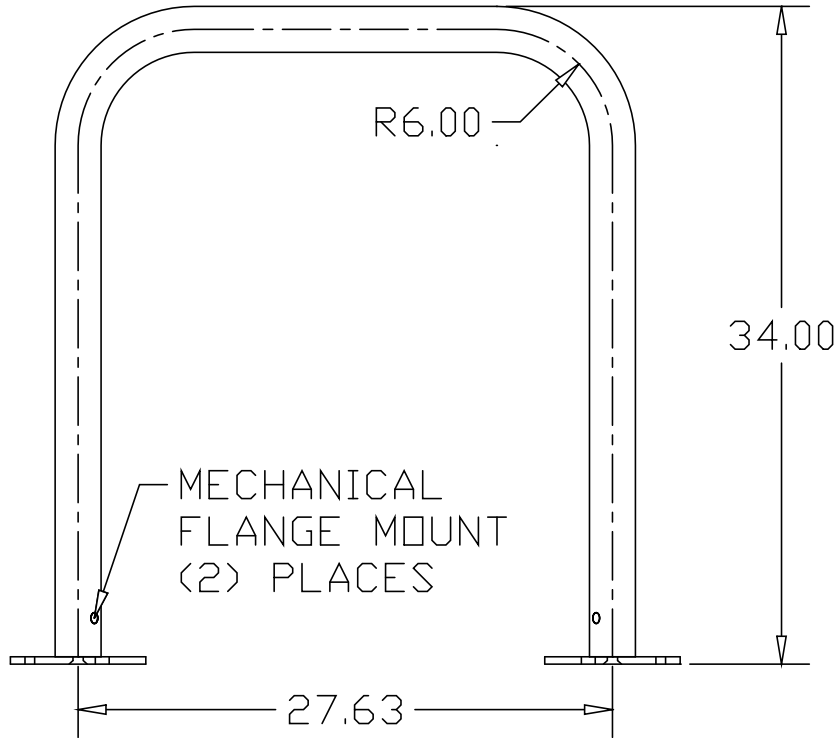

INCHES [MILLIMETERS]

PART NAME		PRE-GALVANIZED BIKE RACK KIT, U-BEND SURFACE MOUNT					
MATERIAL		2.375" OD X .120W GALVANIZED STEEL TUBE					
DATE	02/03/12		THE WAGNER COMPANIES R & B WAGNER, INC. AND J. G. BRAUN CO.				
DRAWN BY	RJF						
FINISH	GALVANIZED						
SIZE	A	WEIGHT	24.63 LBS	PART NUMBER	SR1LW6-SM	REV	