

REV  
SH  
7901  
DWG NO

REVISIONS			
REV	DESCRIPTION	DATE	APPROVED

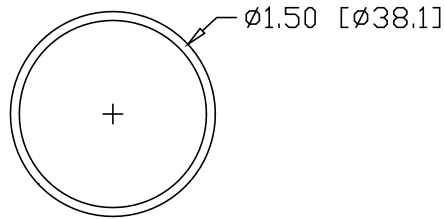
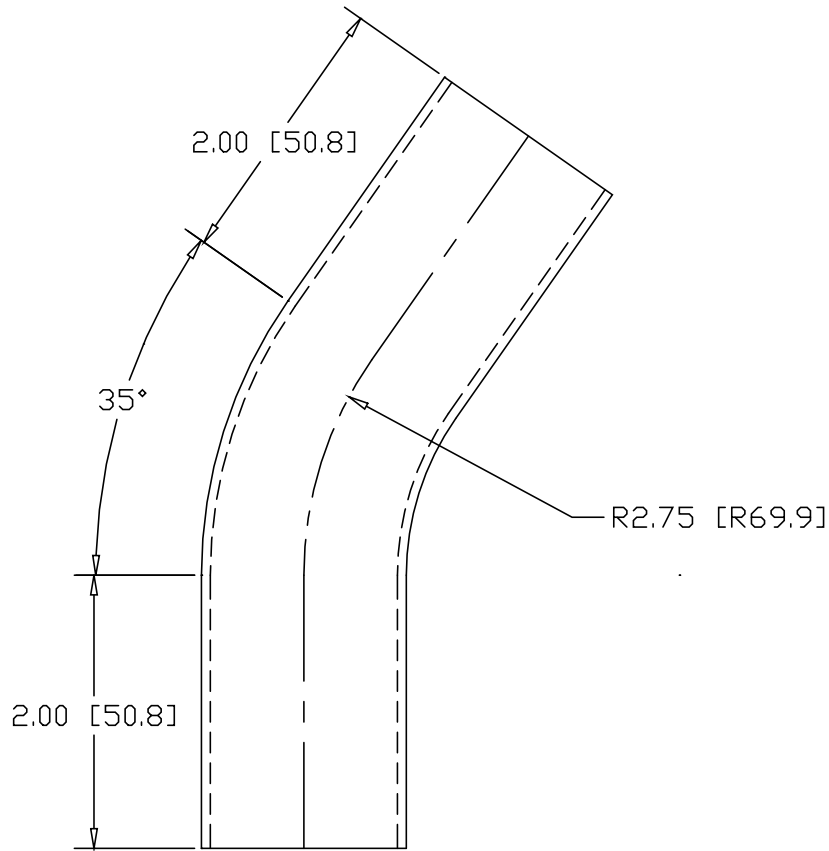

INCHES [MILLIMETERS]

ALTERNATE MATERIAL	PART NUMBER
1.50" O.D. X .125W (6061-T1) ALUMINUM TUBE	7917
1.50" O.D. X .065W (304) STAINLESS STEEL TUBE	7933

PART NAME		1.50" O.D. TUBE 35° ELL X 2.75" CLR W/(2) 2" TANGENTS					
MATERIAL		1.50" O.D. X .065W STEEL TUBE					
DATE	8/15/00						
DRAWN BY	RJF						
FINISH	MILL						
SIZE	A	WEIGHT	.47 LBS	PART NUMBER	7901	REV	