

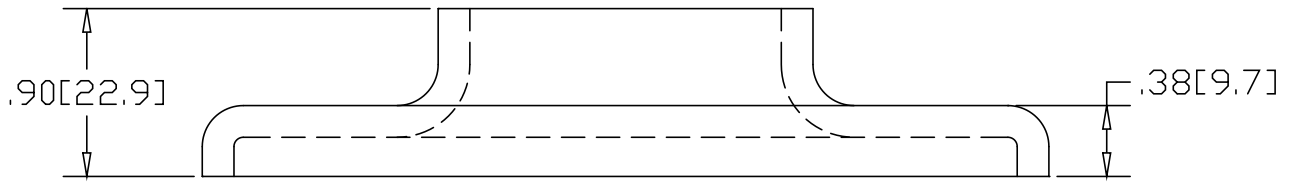

REV
SH
4915
DWG NO

REVISIONS			
REV	DESCRIPTION	DATE	APPROVED

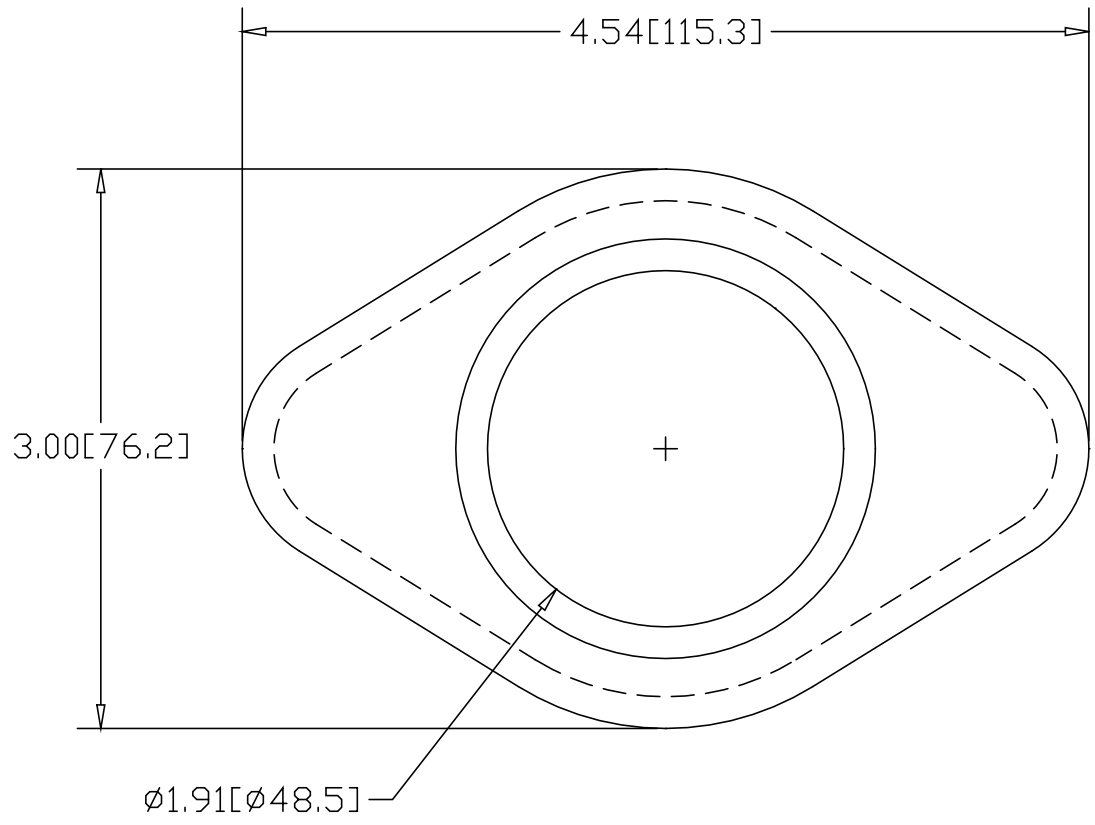

INCHES [MILLIMETERS]

ALTERNATE MATERIAL	PART NUMBER
.190 (3003) ALUMINUM ASTM B209	4945
7 GA. (304) STAINLESS STEEL ASTM A240	4975

PART NAME				1-1/2" PIPE SIZE TAPERED HEAVY BASE FLANGE			
MATERIAL				7 GA. HRP&D STEEL ASTM A569			
DATE	5/22/95	 R & B WAGNER, INC.					
DRAWN BY	RJF						
FINISH	MILL						
SIZE	A	WEIGHT	.47 LBS	PART NUMBER	4915	REV	