

2



1

PARTS LIST

ITEM	QTY	PART NUMBER	DESCRIPTION
1	1	SHC3N2520-0300	SCREW SS 1/4-20 X 3.00 SOCKET HEAD
2	1	WR3166SFB	BRACKET SLIP FIT BARREL BRACKET MOUNT
3	1	WR3166SFC	BRACKET SLIP STRIP CLAMP BRACKET MOUNT
4	1	WR3166SFVARM	BRACKET SLIP FIT VERTICAL POST SS
5	1	WR3166SFHUB	Handrail Bracket Hub, SS, Cast, 1.50 in W/ 3/8 in Threaded Hole, #4 Satin Finish
6	1	WR3168SFHARM	Handrail Bracket Arm, SS, Cast, Horizontal, .75 in Dia, 2.875 in Long, #4 Satin
7	1	WR3900D	HANDRAIL, BRACKET WALL MOUNT DISK, 1.9 in
8	1	GB4389K	HANDRAIL BRACKET GLASS MOUNT ADAPTER ASSY, SS, 1.90 DIA, FOR 1/2" GLASS

B

B

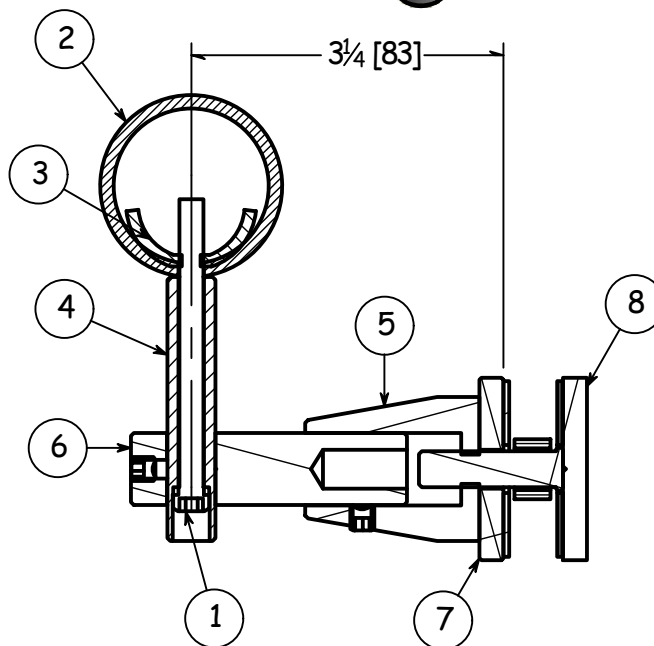
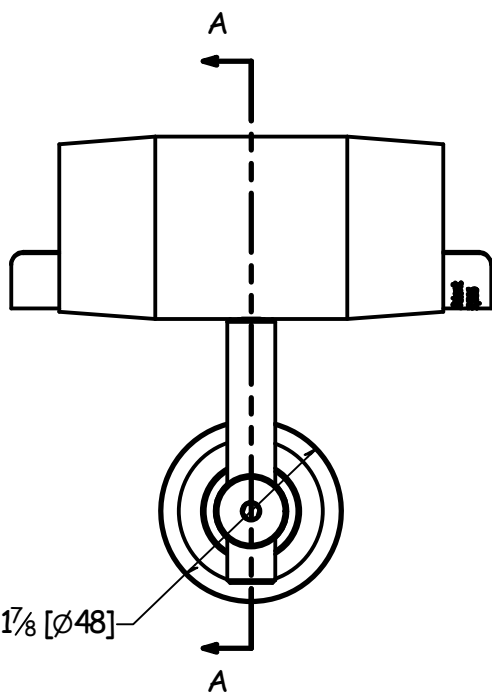
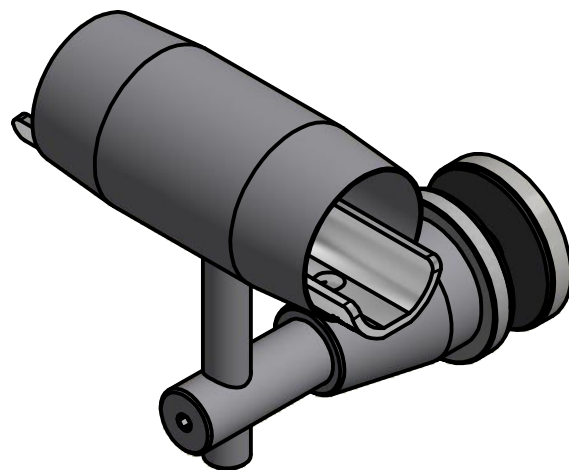

A

A

SECTION A-A

U.S. Patent #
8,757,566

REVISION HISTORY		
REV	DESCRIPTION	DATE
1	ADDED CAST COMPONENTS	1/8/2014

CUT LENGTH:	DESCRIPTION: BRACKET ASSEMBLY SLIP FIT, GLASS MOUNT, KIT	
DEVELOPED LENGTH:	DATE: 1/8/2014	MATERIAL DESC:
TOOL NUMBER:	DRAWN BY: rknepprath	
	FINISH: #4	
	SIZE: A	WEIGHT: N/A
		PART NUMBER: GR3166SF
		REV: 1



THE WAGNER COMPANIES
R & B WAGNER, INC. AND J. G. BRAUN CO.

2



1