

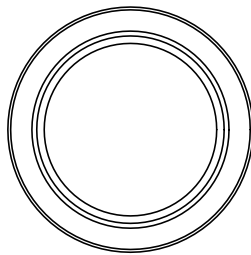

REV
SH
3210M
DWG NO

REVISIONS			
REV	DESCRIPTION	DATE	APPROVED

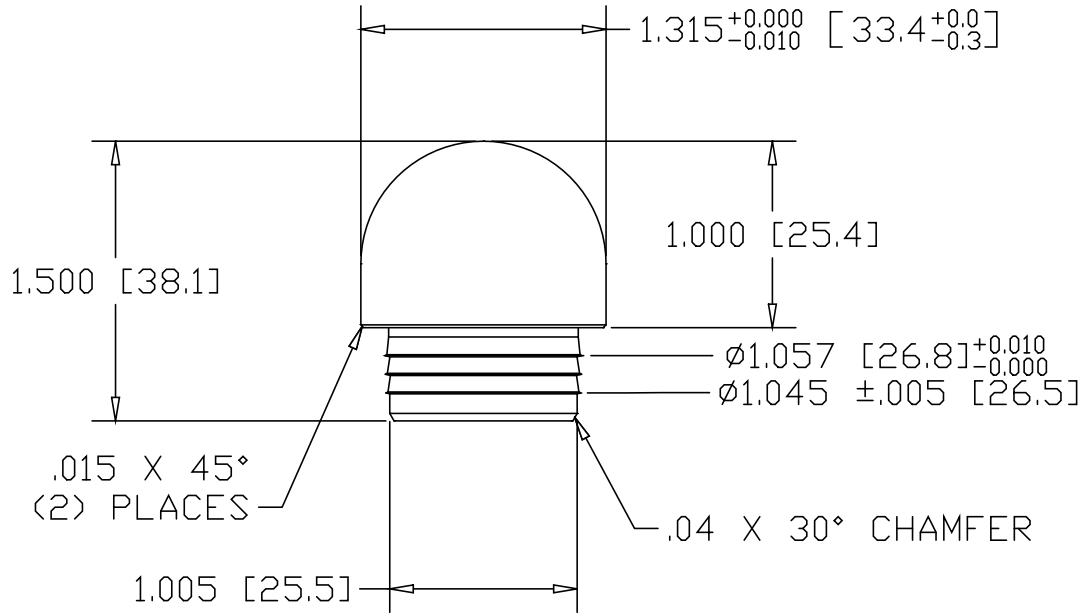

INCHES [MILLIMETERS]

PART NAME 1" PIPE SIZE TYPE-A MACHINED DRIVE-ON CAP			
MATERIAL 1018 STEEL BAR			
DATE 04/20/05		THE WAGNER COMPANIES	
DRAWN BY RJF		R & B WAGNER, INC. AND J. G. BRAUN CO.	
FINISH MILL		SIZE A	WEIGHT .47 LBS
			REV