

REV
SH
8917
DWG NO

REVISIONS			
REV	DESCRIPTION	DATE	APPROVED

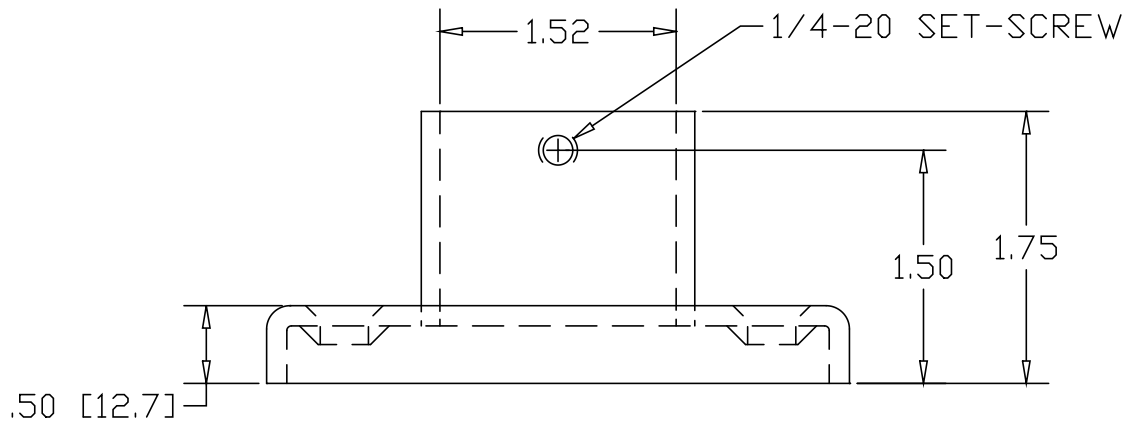
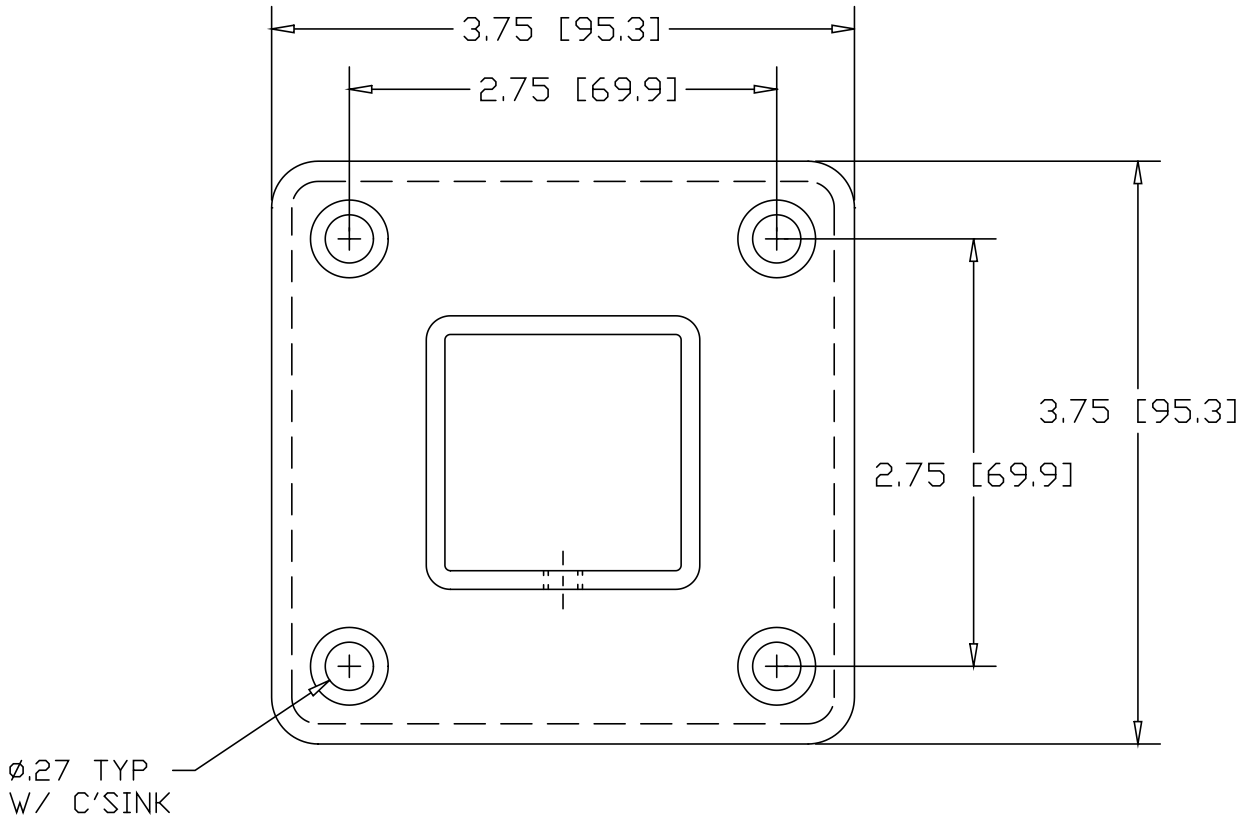

INCHES [MILLIMETERS]

ALTERNATE MATERIAL	PART NUMBER
.125 (3003) ALUMINUM ASTM B-209	8941

PART NAME 1-1/2" SQUARE TUBE SOCKET FLANGE W/ (4) HOLES AND SET-SCREW			
MATERIAL 10 GA. HRP&D STEEL ASTM A-569			
DATE 3/16/95	WAGNER	R & B WAGNER, INC.	
DRAWN BY RJF			
FINISH MILL	SIZE A	WEIGHT .79 LBS	PART NUMBER 8917
			REV