

REV  
SH  
9308  
DWG NO

REVISIONS			
REV	DESCRIPTION	DATE	APPROVED

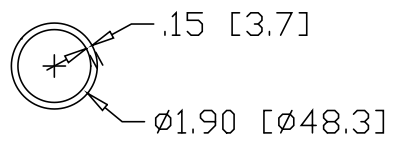
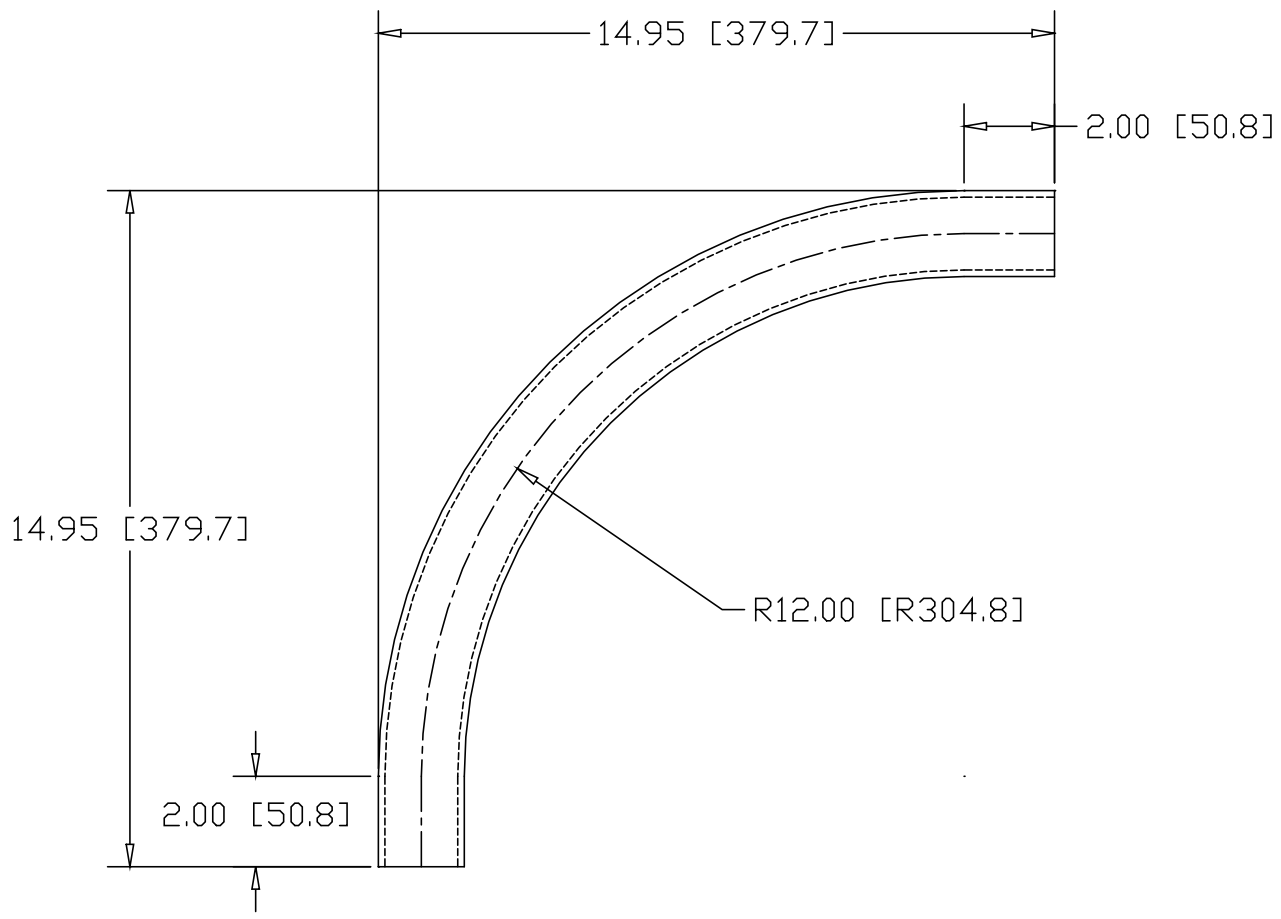

INCHES [MILLIMETERS]

ALTERNATE MATERIAL	PART NUMBER
1-1/2" SCH 40 (6063) ALUMINUM PIPE	9322
1-1/2" SCH 40 (304) STAINLESS STEEL PIPE	9336

PART NAME 1-1/2" PIPE SIZE 90° ELL X 11.05" I.R. W/ (2) 2" TANGENTS			
MATERIAL 1-1/2" SCH 40 A53 STEEL PIPE			
DATE 8/16/01	<b>WAGNER</b>	R & B WAGNER, INC.	
DRAWN BY JAH			
FINISH MILL			
SIZE A	WEIGHT 5.14 LBS	PART NUMBER 9308	REV