

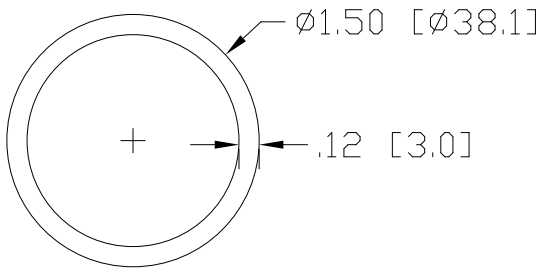

REV
SH
DWG NO 7909.120

REVISIONS			
REV	DESCRIPTION	DATE	APPROVED

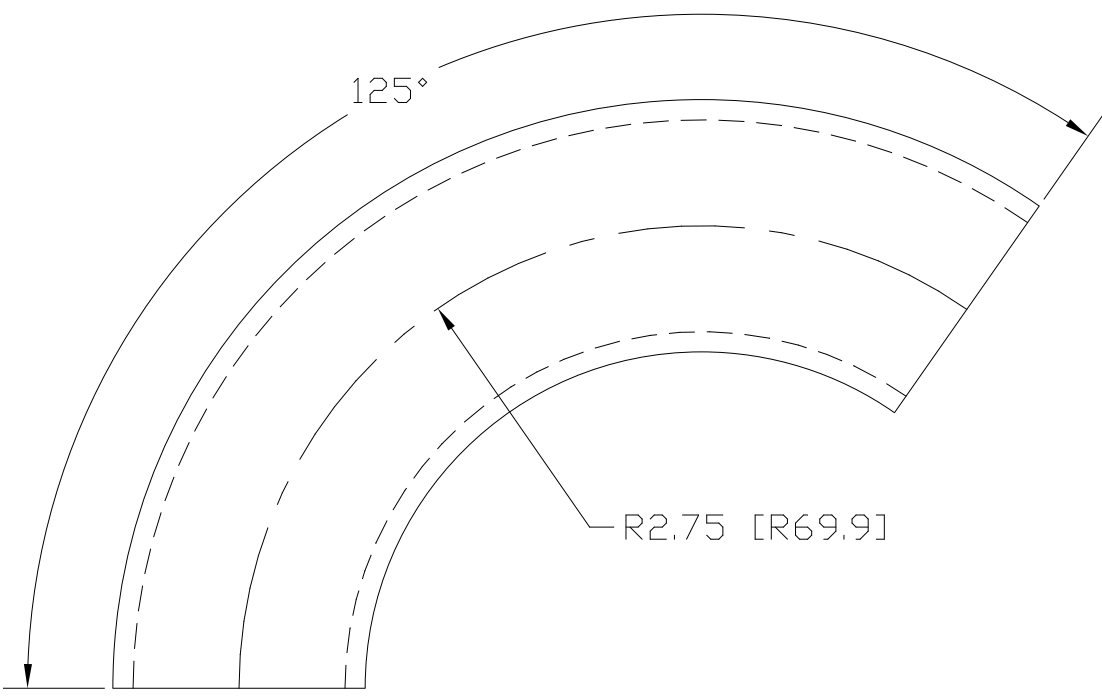

INCHES [MILLIMETERS]

PART NAME		1.50" O.D. TUBE 125° ELL X 2.75" CLR			
MATERIAL		1.50" O.D. X .120W STEEL TUBE			
DATE	8/15/00	 THE WAGNER COMPANIES R & B WAGNER, INC. AND J. G. BRAUN CO.			
DRAWN BY	RJF				
FINISH	MILL				
SIZE	A	WEIGHT	.89 LBS	PART NUMBER	7909.120
				REV	