

REV  
SH  
DWG NO 90161B

REVISIONS			
REV	DESCRIPTION	DATE	APPROVED

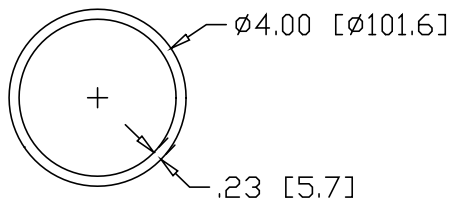
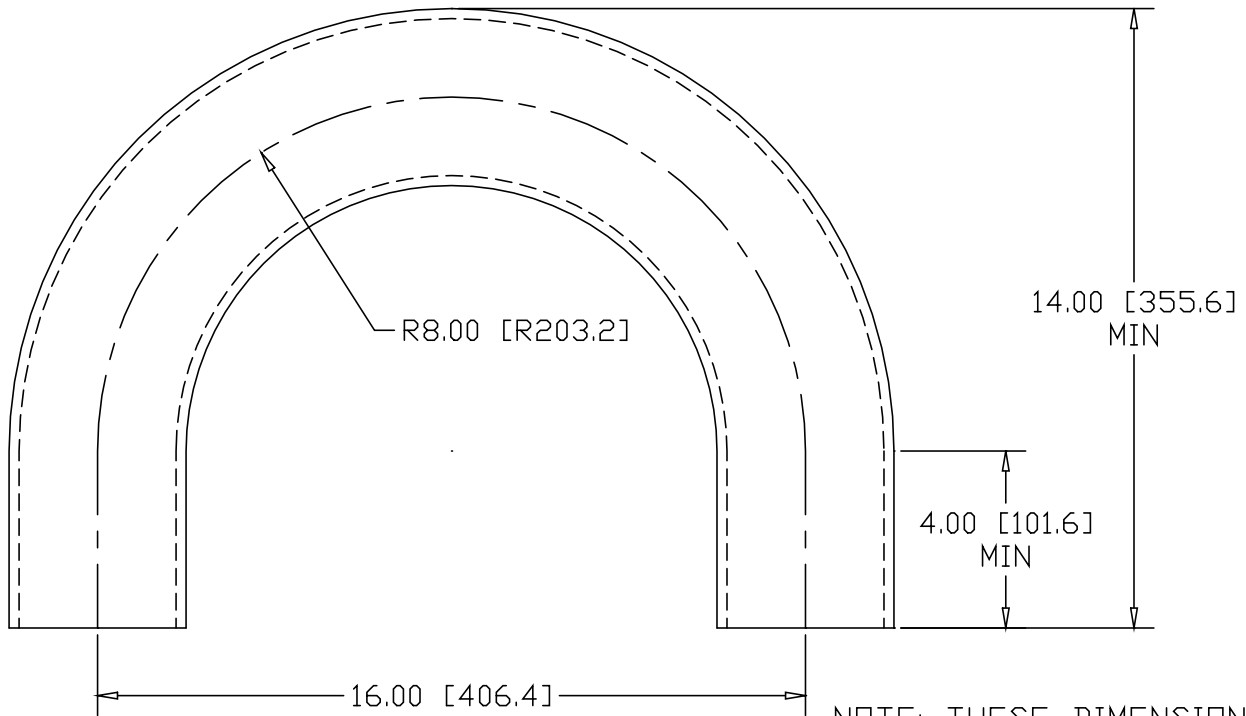

NOTE: THESE DIMENSIONS ARE MINIMUM ENDS ARE LEFT LONG

INCHES MILLIMETERS

ALTERNATE MATERIAL	PART NUMBER
3-1/2" SCH 40 6063 ALUMINUM PIPE	91161B
3-1/2" SCH 40 (304) STAINLESS STEEL PIPE	92161B

PART NAME		3-1/2" SCH 40 8" CLR 180° BEND W/(2) 4" TANGENTS					
MATERIAL		3-1/2" SCH 40 STEEL PIPE A53					
DATE	9-03-03	 <b>THE WAGNER COMPANIES</b> R & B WAGNER, INC. AND J. G. BRAUN CO.					
DRAWN BY	RJF						
FINISH	MILL						
SIZE	A	WEIGHT	25.15 LBS	PART NUMBER	90161B	REV	