

REV
SH
D173
DWG NO

REVISIONS

REV	DESCRIPTION	DATE	APPROVED
-----	-------------	------	----------

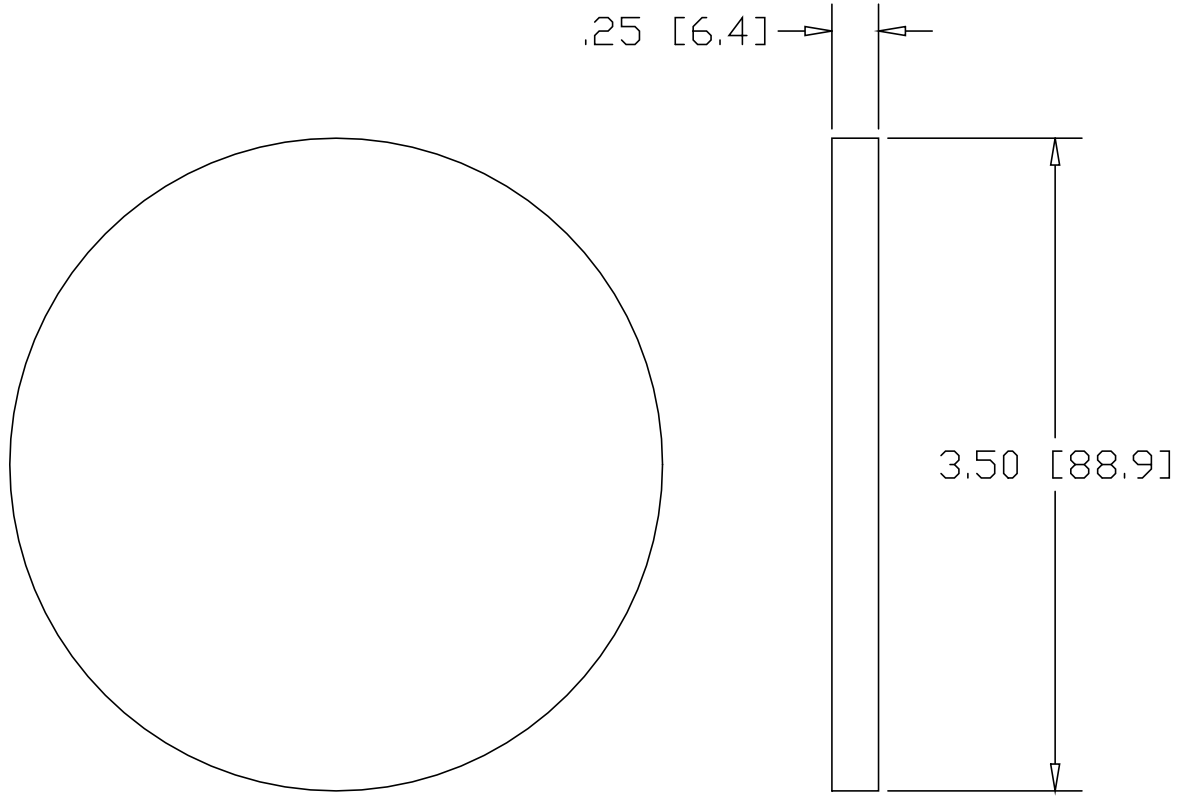

INCHES[MILLIMETERS]

ALTERNATE MATERIAL	PART NUMBER
.250 (3003) ALUMINUM ASTM B209	D174
.250 (304) STAINLESS STEEL ASTM A240	D175
.250 (260) BRASS ASTM B19,B36	D176
.250 (280) MUNTZ METAL	D176M

PART NAME		3.50" OD TUBE SIZE TYPE-D WELD-ON DISK		
MATERIAL		.250 HRP&D STEEL ASTM A569		
DATE	11/20/98	 THE WAGNER COMPANIES R & B WAGNER, INC. AND J. G. BRAUN CO.		
DRAWN BY	RJF			
FINISH	MILL			
SIZE	WEIGHT	PART NUMBER	REV	
A	.67 LBS	D173		