

REV  
SH  
1103-2  
DWG NO

REVISIONS			
REV	DESCRIPTION	DATE	APPROVED

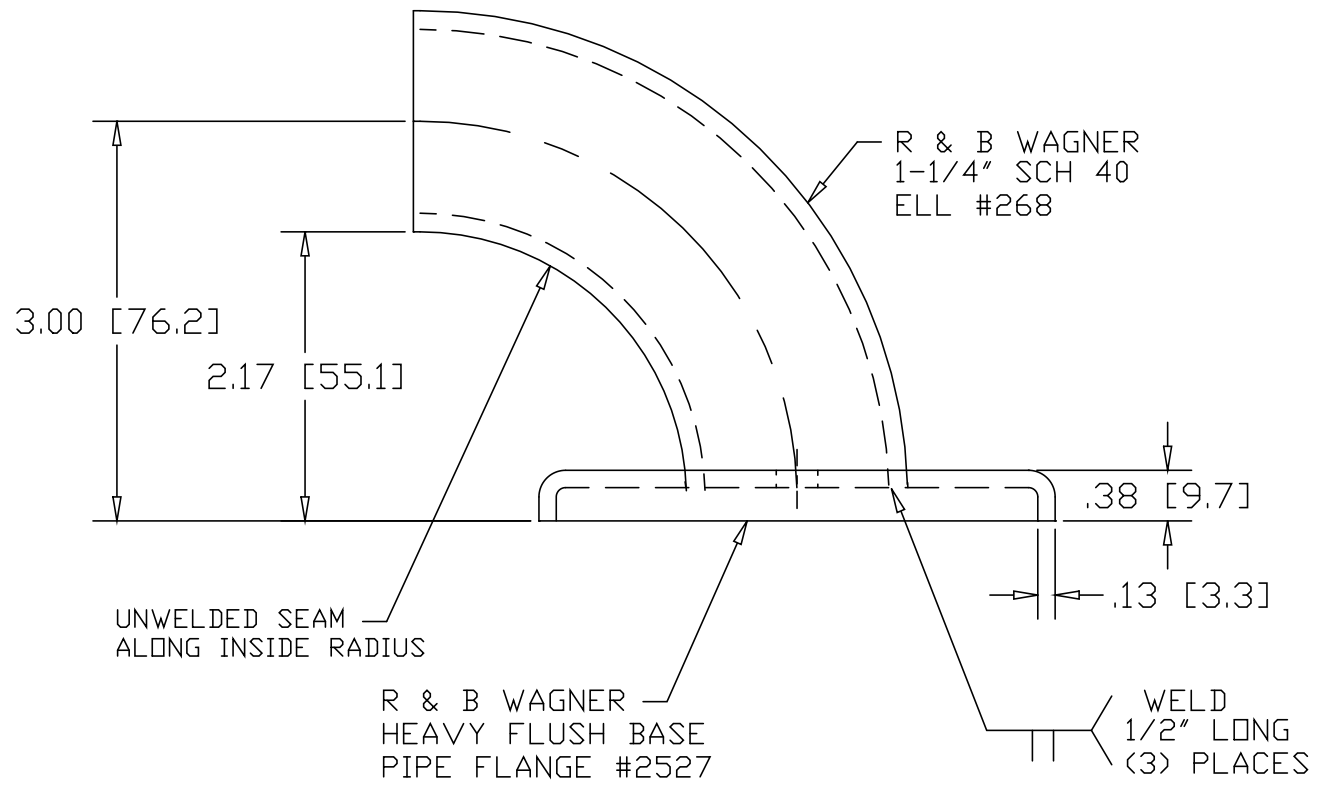
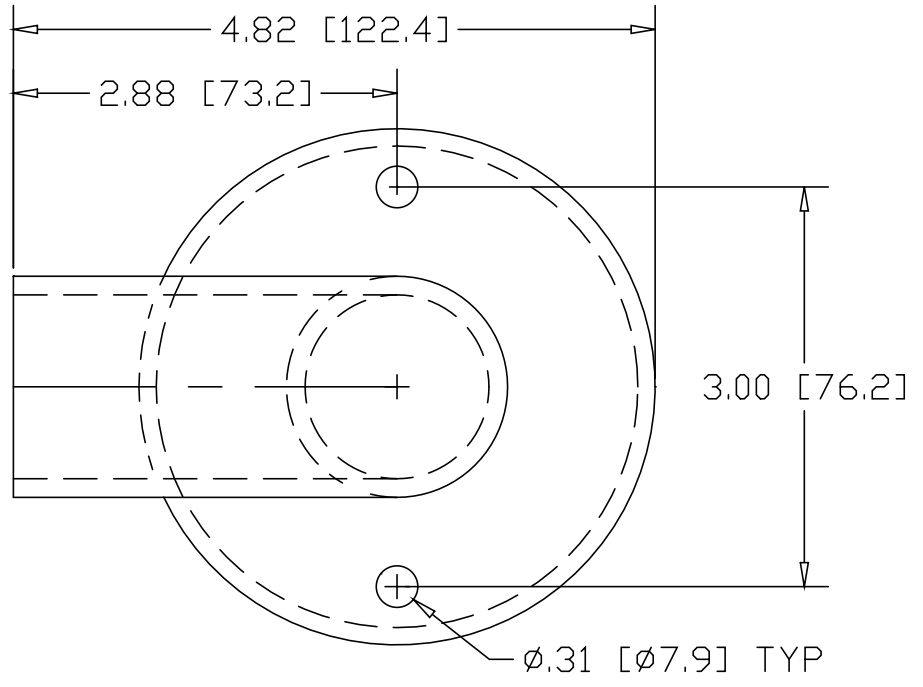

INCHES [MILLIMETERS]

PART NAME 1-1/4" PIPE SIZE X 3.00CL WALL RETURN W/2 HOLES			
MATERIAL STEEL - ASTM A569			
DATE 8/07/02		<b>THE WAGNER COMPANIES</b> R & B WAGNER, INC. AND J. G. BRAUN CO.	
DRAWN BY JAH			
FINISH MILL			
SIZE A	WEIGHT	PART NUMBER 1103-2	REV