

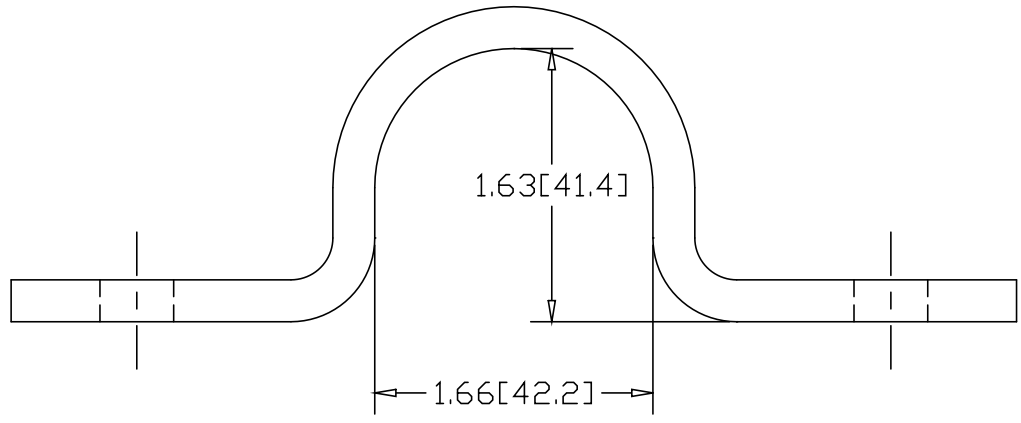

REV
SH
3750
DWG NO

REVISIONS			
REV	DESCRIPTION	DATE	APPROVED

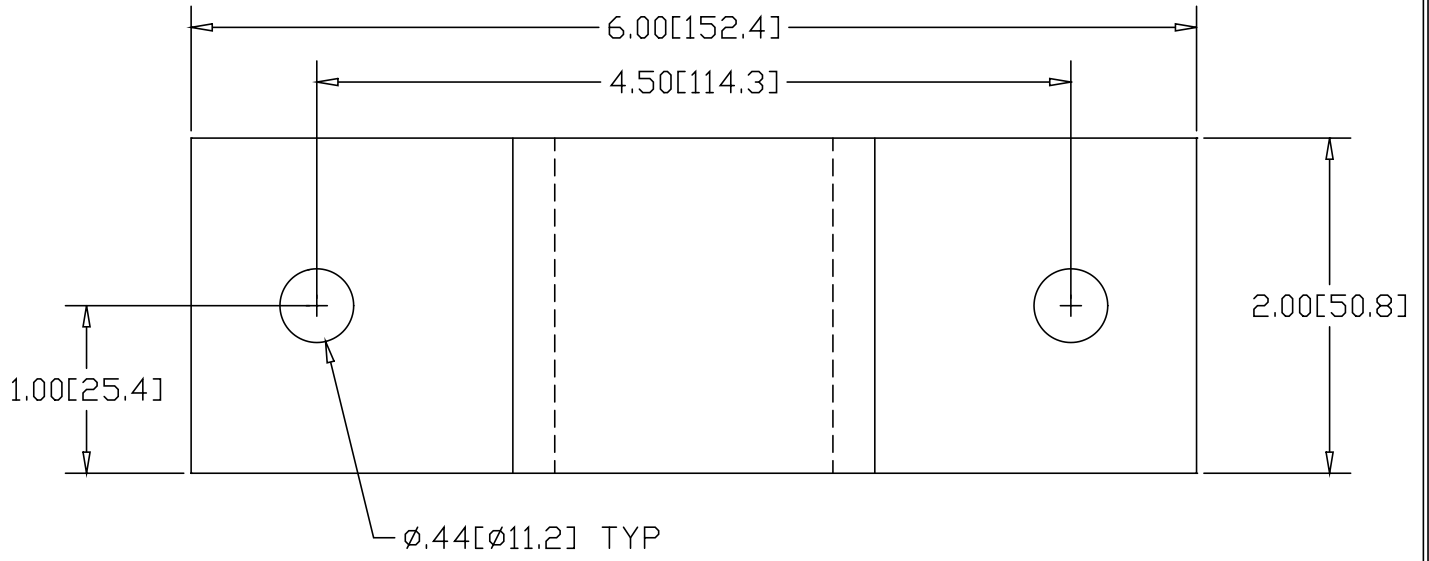

INCHES [MILLIMETERS]

ALTERNATE MATERIAL		PART NUMBER					
.250 (3003) ALUMINUM ASTM B209		3756					
7 GA. (304) STAINLESS STEEL ASTM A240		3762-SS					
PART NAME 1-1/4" PIPE (1.66" OD) X 2" WIDE U-BRACKET W/(2) HOLES							
MATERIAL .250 HRP&O STEEL ASTM A569							
DATE	1/13/00	 THE WAGNER COMPANIES R & B WAGNER, INC. AND J. G. BRAUN CO.					
DRAWN BY	RJF						
FINISH	MILL						
SIZE	A	WEIGHT	1.02 LBS	PART NUMBER	3750	REV	