

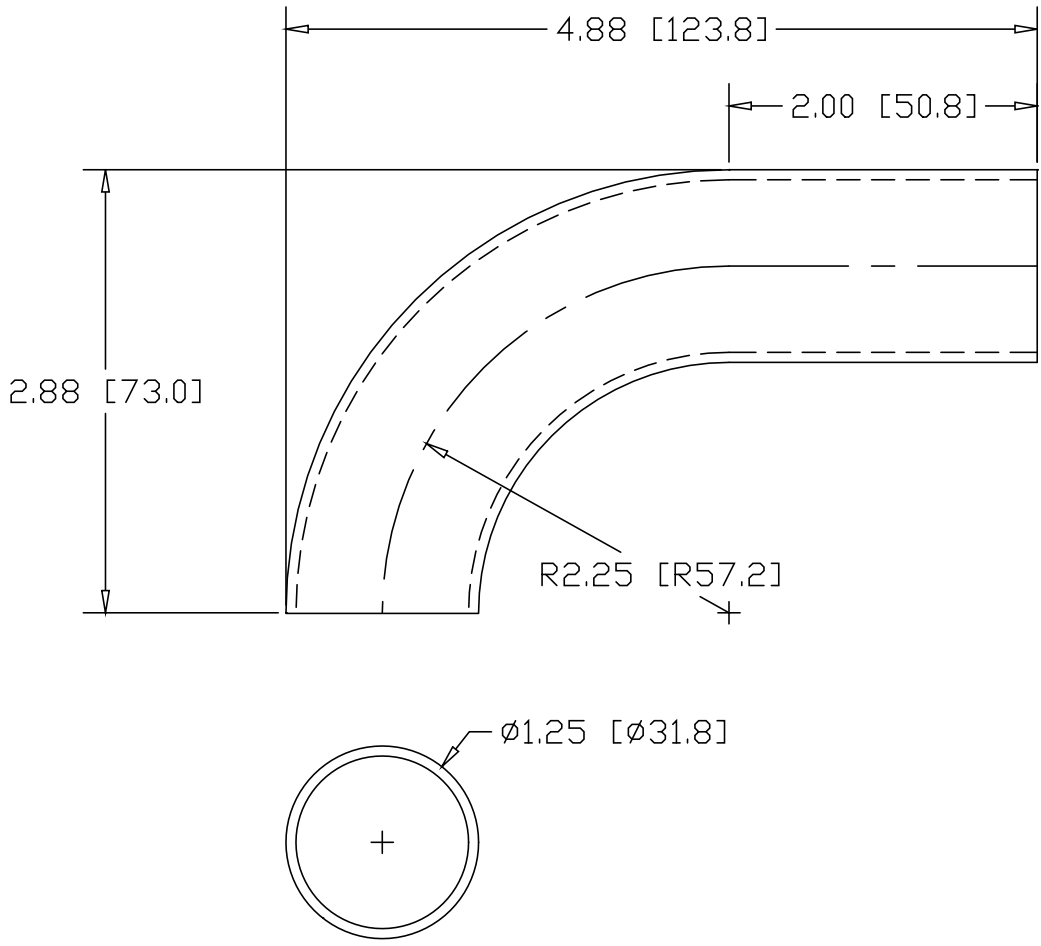

REV  
SH  
7857  
DWG NO

REVISIONS			
REV	DESCRIPTION	DATE	APPROVED



INCHES [MILLIMETERS]

ALTERNATE MATERIAL	PART NUMBER
1.25" O.D. X .125W (6061-T1) ALUMINUM TUBE	7873
1.25" O.D. X .065W (304) STAINLESS STEEL TUBE	7889T

PART NAME 1.25" O.D. TUBE 90° ELL X 2.25" CLR W/(1) 2" TANGENT			
MATERIAL 1.25" O.D. X .065W STEEL TUBE			
DATE 8/15/00	 <b>R &amp; B WAGNER, INC.</b>		
DRAWN BY RJF			
FINISH MILL			
SIZE A	WEIGHT .38 LBS	PART NUMBER 7857	REV