

2

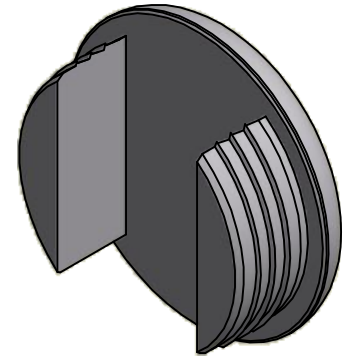

1

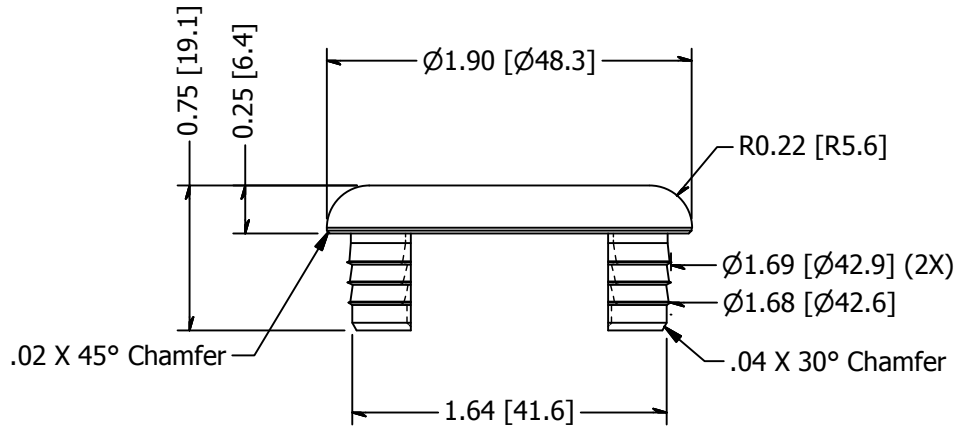

B

B

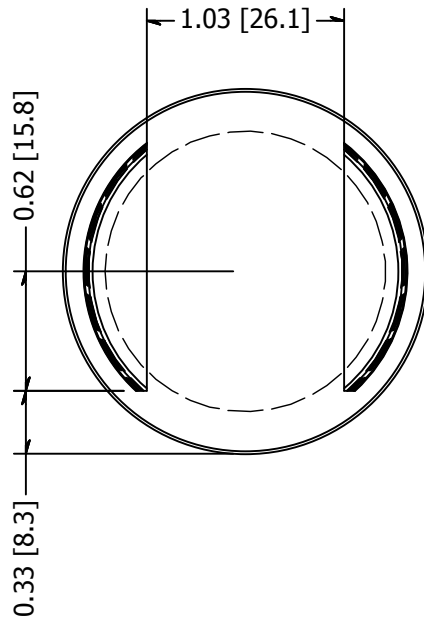

A

A

TOLERANCE UNLESS OTHERWISE NOTED, TOLERANCES TO CONFORM TO ES.03.011	CUT LENGTH:	FINISH: #4 Satin	DESCRIPTION: CAP AL 1.90 CAPRAIL DRIVE-ON 63T52 MACHINED #4	
	DEVELOPED LENGTH:	WEIGHT: 0.09 lbmass	MATERIAL: Aluminum 6063	MATERIAL DESC: 6063-T52 ALUMINUM
	TOOL NUMBER:		DATE: 3/6/2018	REV: -
			DRAWN BY: T. Kolbach	WAGNER ™ 10600 W Brown Deer Rd Milwaukee, WI 53224 COLLABORATIVE METALWORKS http://www.wagnercompanies.com/
		PART NUMBER: GR2190EM		

2



1