

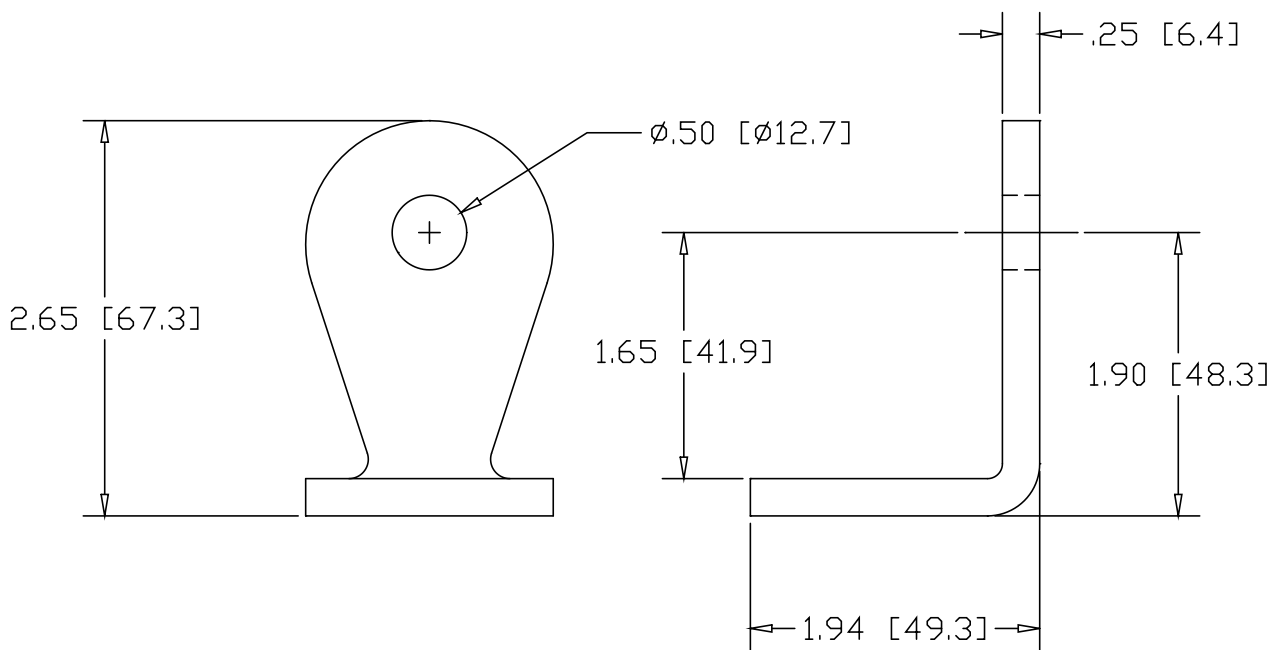

REV
SH
5020
DWG NO

REVISIONS			
REV	DESCRIPTION	DATE	APPROVED

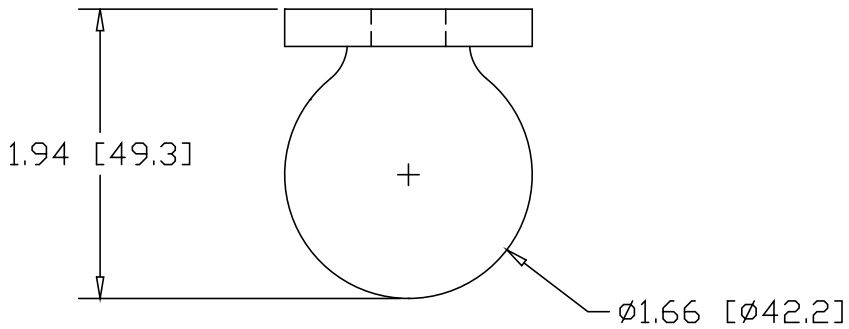

PART NAME		1-1/4" WELD-ON POST BRACKET					
MATERIAL		.250 HRP&D STEEL ASTM A569					
DATE	9/12/03		THE WAGNER COMPANIES R & B WAGNER, INC. AND J. G. BRAUN CO.				
DRAWN BY	RJF						
FINISH	MILL						
SIZE	A	WEIGHT	.38 LBS	PART NUMBER	5020	REV	