

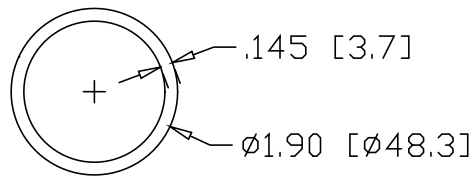

REV  
SH  
DWG NO 5663-3

REVISIONS			
REV	DESCRIPTION	DATE	APPROVED

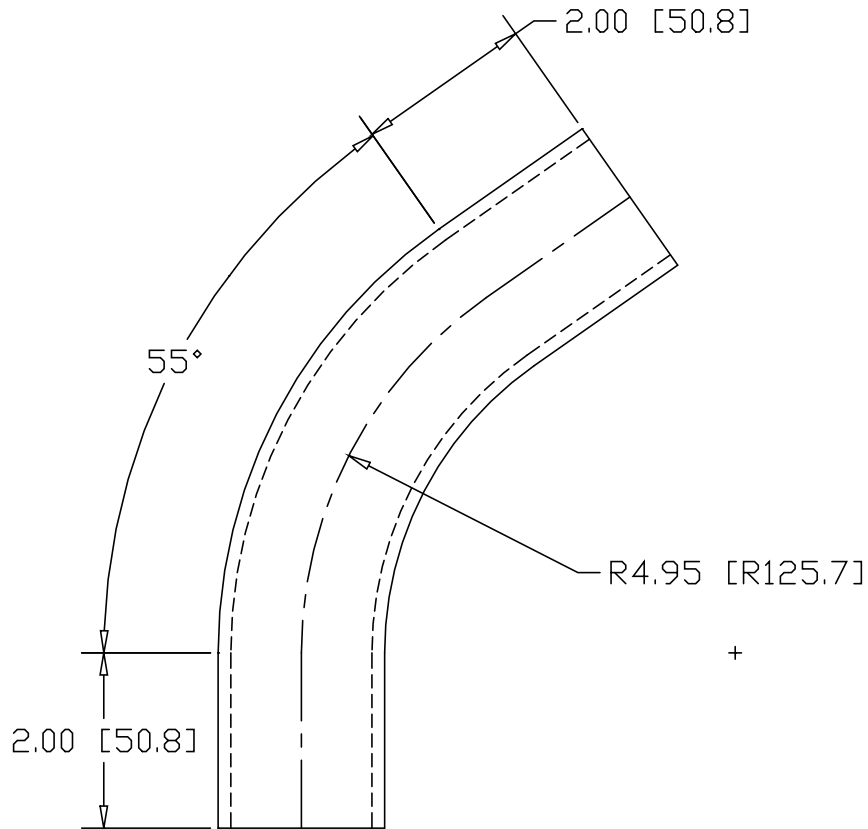

INCHES [MILLIMETERS]

PART NAME 1-1/2" PIPE SIZE 55° ELL X 4" I.R. W/ (2) 2" TANGENTS			
MATERIAL 1-1/2" SCH 40 A53 STEEL PIPE			
DATE	4/5/96	 <b>THE WAGNER COMPANIES</b> R & B WAGNER, INC. AND J. G. BRAUN CO.	
DRAWN BY	RJF		
FINISH	MILL		
SIZE	A	WEIGHT	1.97 LBS
		PART NUMBER	5663-3
			REV