

REV  
SH  
5605  
DWG NO

REVISIONS			
REV	DESCRIPTION	DATE	APPROVED

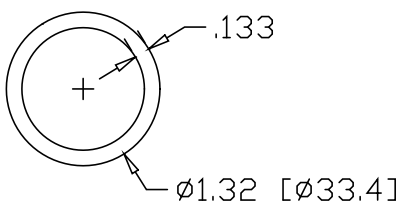
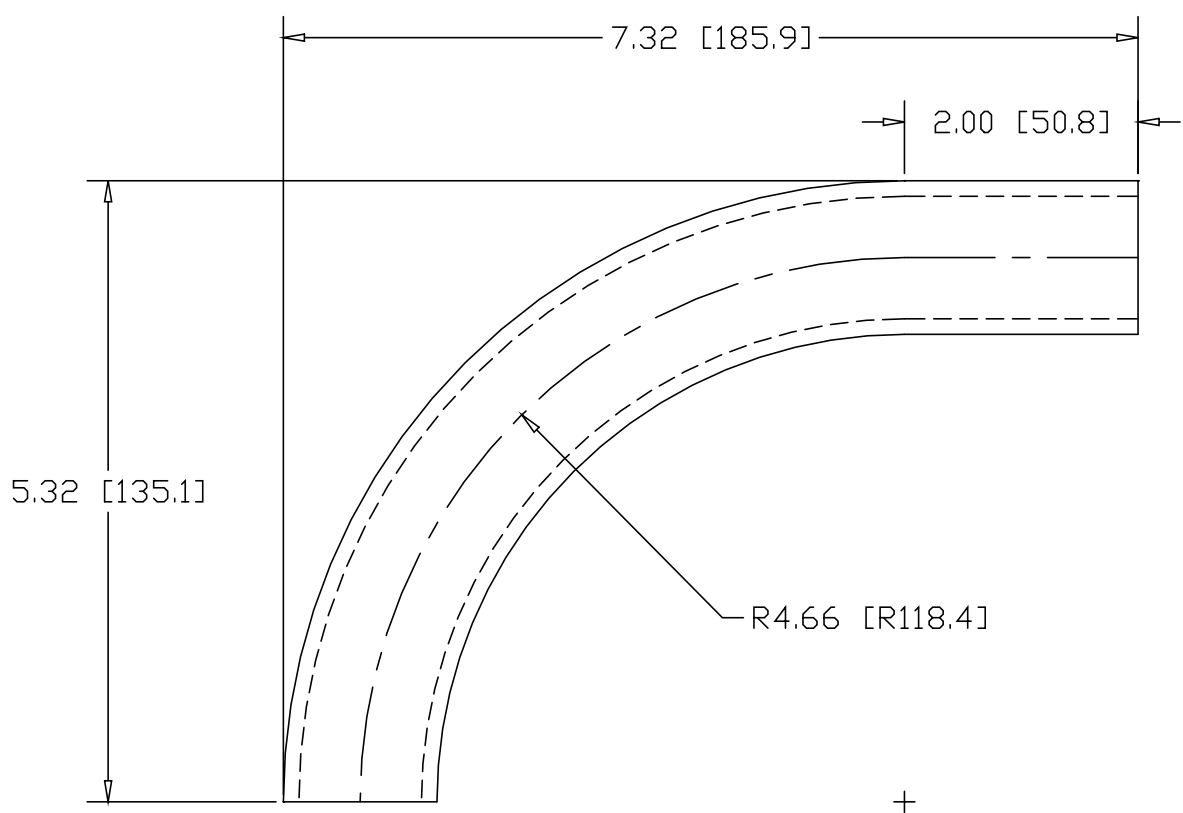

INCHES [MILLIMETERS]

ALTERNATE MATERIAL	PART NUMBER
1" SCH 40 (6063) ALUMINUM PIPE	5615
1" SCH 40 (304) STAINLESS STEEL PIPE	5625

PART NAME 1" PIPE SIZE 90° ELL X 4" I.R. W/ (1) 2" TANGENT			
MATERIAL 1" SCH 40 A53 STEEL PIPE			
DATE 4/5/96	<b>WAGNER</b>	R & B WAGNER, INC.	
DRAWN BY RJF			
FINISH MILL			
SIZE A	WEIGHT 1.30 LBS	PART NUMBER 5605	REV