

REV
SH
6956
DWG NO

REVISIONS			
REV	DESCRIPTION	DATE	APPROVED

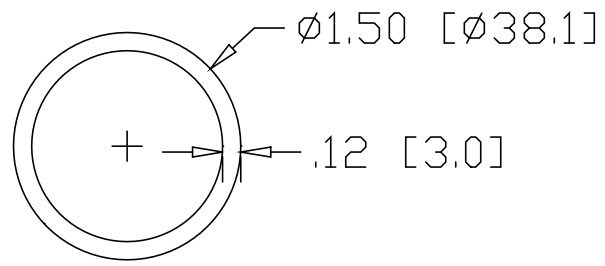
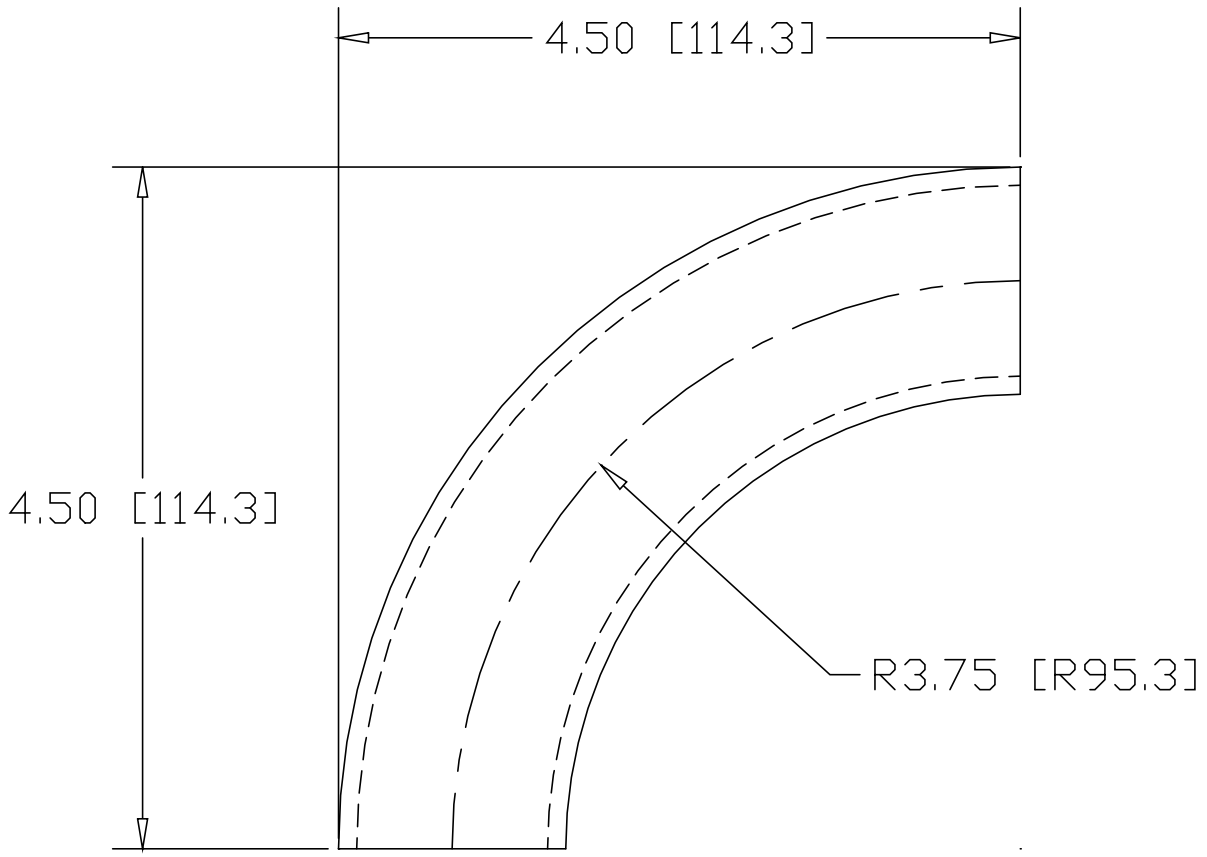

INCHES [MILLIMETERS]

ALTERNATE MATERIAL	PART NUMBER
1.50" O.D. X .125W (6061-T1) ALUMINUM TUBE	6967
1.50" O.D. X .120W (304) STAINLESS STEEL TUBE	6975

PART NAME		1.50" O.D. TUBE 90° ELL X 3.75" CLR					
MATERIAL		1.50" O.D. X .120W STEEL TUBE					
DATE	9/22/00						
DRAWN BY	RJF						
FINISH	MILL						
SIZE	A	WEIGHT	.87 LBS	PART NUMBER	6956	REV	