

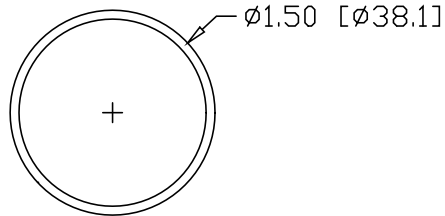

REV
SH
7906
DWG NO

REVISIONS			
REV	DESCRIPTION	DATE	APPROVED

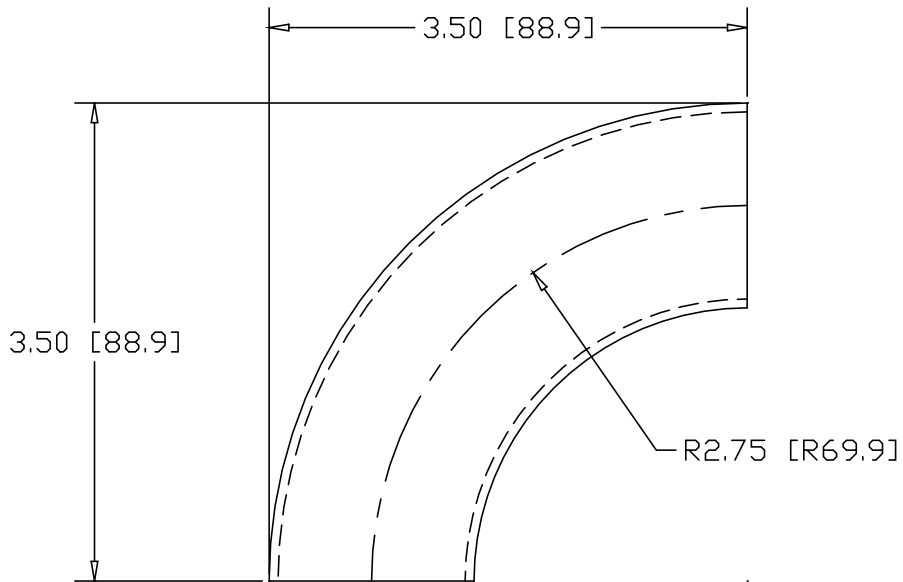

INCHES [MILLIMETERS]

ALTERNATE MATERIAL	PART NUMBER
1.50" O.D. X .125W (6061-T1) ALUMINUM TUBE	7922
1.50" O.D. X .065W (304) STAINLESS STEEL TUBE	7938

PART NAME		1.50" O.D. TUBE 90° ELL X 2.75" CLR					
MATERIAL		1.50" O.D. X .065W STEEL TUBE					
DATE	8/15/00	 R & B WAGNER, INC.					
DRAWN BY	RJF						
FINISH	MILL						
SIZE	A	WEIGHT	.36 LBS	PART NUMBER	7906	REV	