

REV
SH
DWG NO 4185

REVISIONS			
REV	DESCRIPTION	DATE	APPROVED

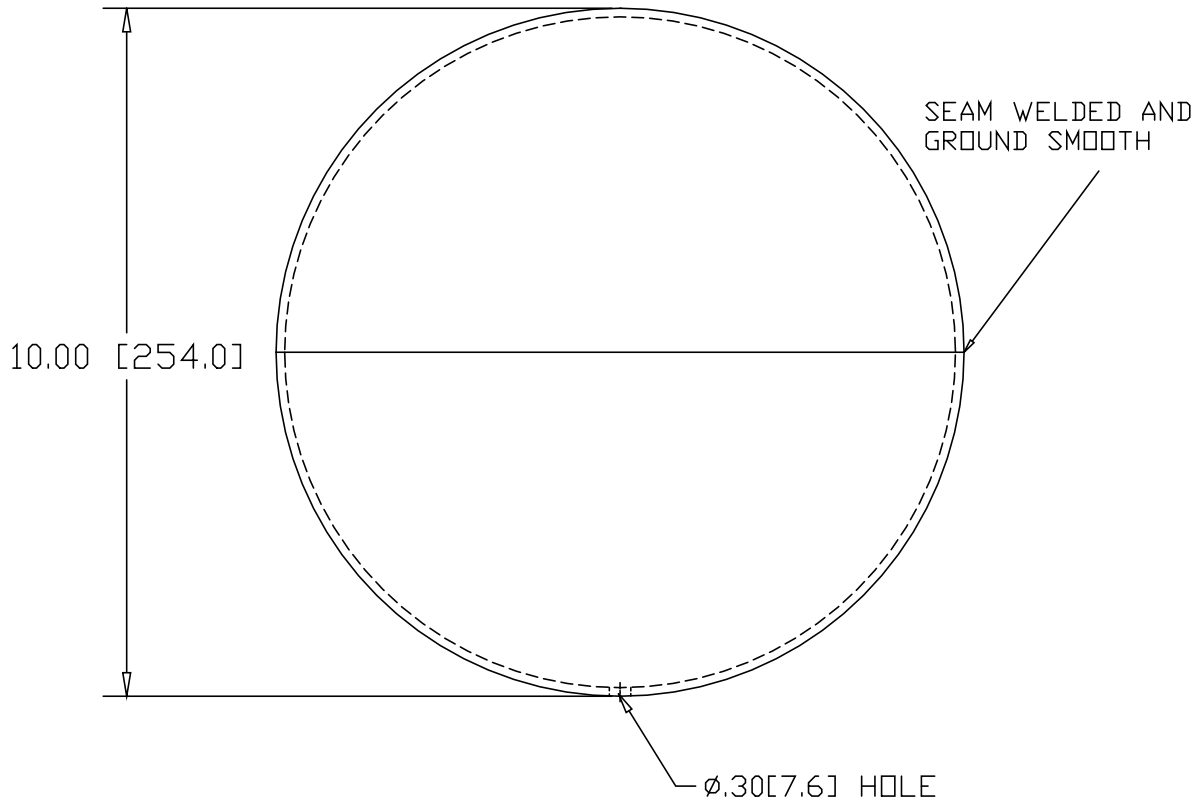

INCHES [MILLIMETERS]

ALTERNATE MATERIAL	PART NUMBER
.125 (3003) ALUMINUM SHEET ASTM B209	4187
11 GA. (.1200) 304 STAINLESS STEEL A240	4188
.125 (260) BRASS	4189
.125 (655) SILICON BRONZE	SB4185

PART NAME		10.00" DIAMETER HOLLOW BALL					
MATERIAL		11 GA. (.1196) HRP&D STEEL SHEET ASTM A569					
DATE	1/4/00		THE WAGNER COMPANIES R & B WAGNER, INC. AND J. G. BRAUN CO.				
DRAWN BY	RJF						
FINISH	MILL						
SIZE	A	WEIGHT	10.00 LBS	PART NUMBER	4185	REV	