

REVISIONS			
REV	DESCRIPTION	DATE	APPROVED
A	REVISED SADDLE	1/20/06	RDC
B	BOLT WAS 2.00" LONG	04/20/06	RJF

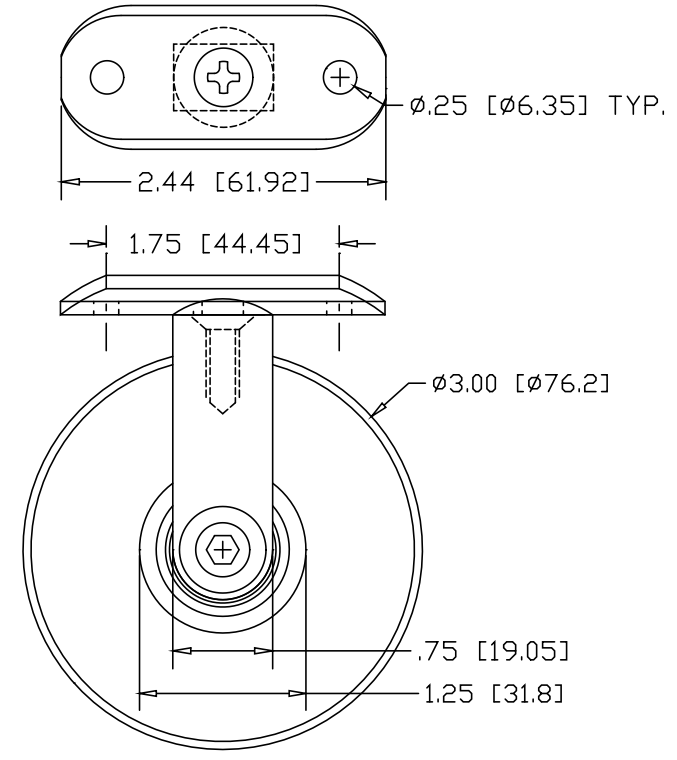

3/8-16 X 1.50" #6841
BUTTON HEAD BOLT

INCHES [MILLIMETERS]

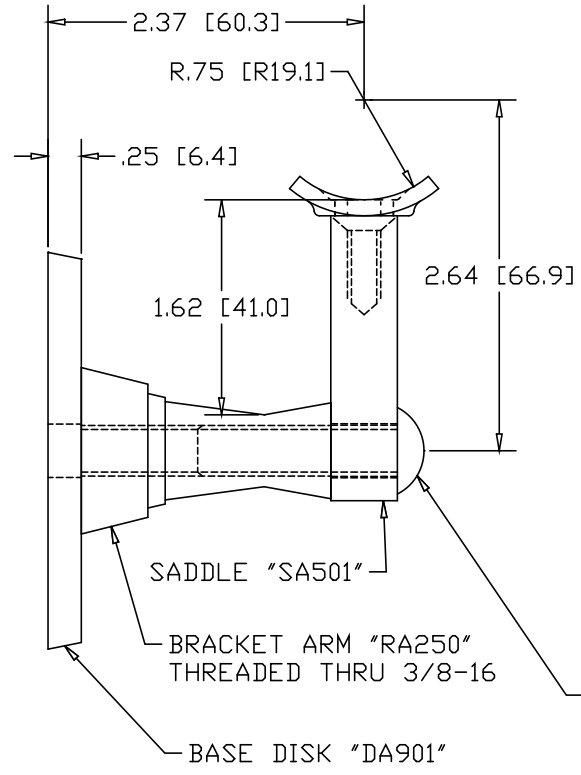
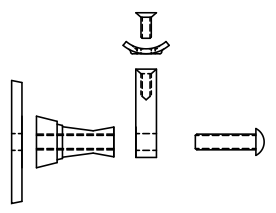

EXPLODED VIEW

PART NAME		MACHINED BRACKET, WALL MOUNT		
MATERIAL		6063 ALUMINUM		
DATE	9/15/03		THE WAGNER COMPANIES R & B WAGNER, INC. AND J. G. BRAUN CO.	
DRAWN BY	RJF			
FINISH	#6 SATIN	SIZE	WEIGHT	PART NUMBER
		A		MB2251W
				REV B