

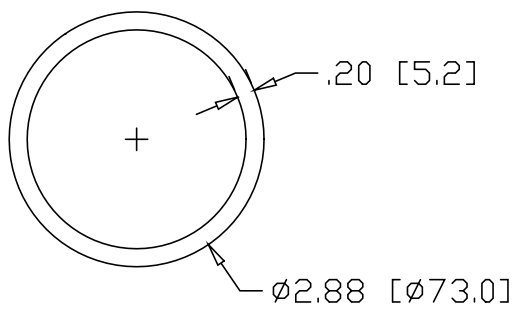

REV
SH
9600
DWG NO

REVISIONS			
REV	DESCRIPTION	DATE	APPROVED

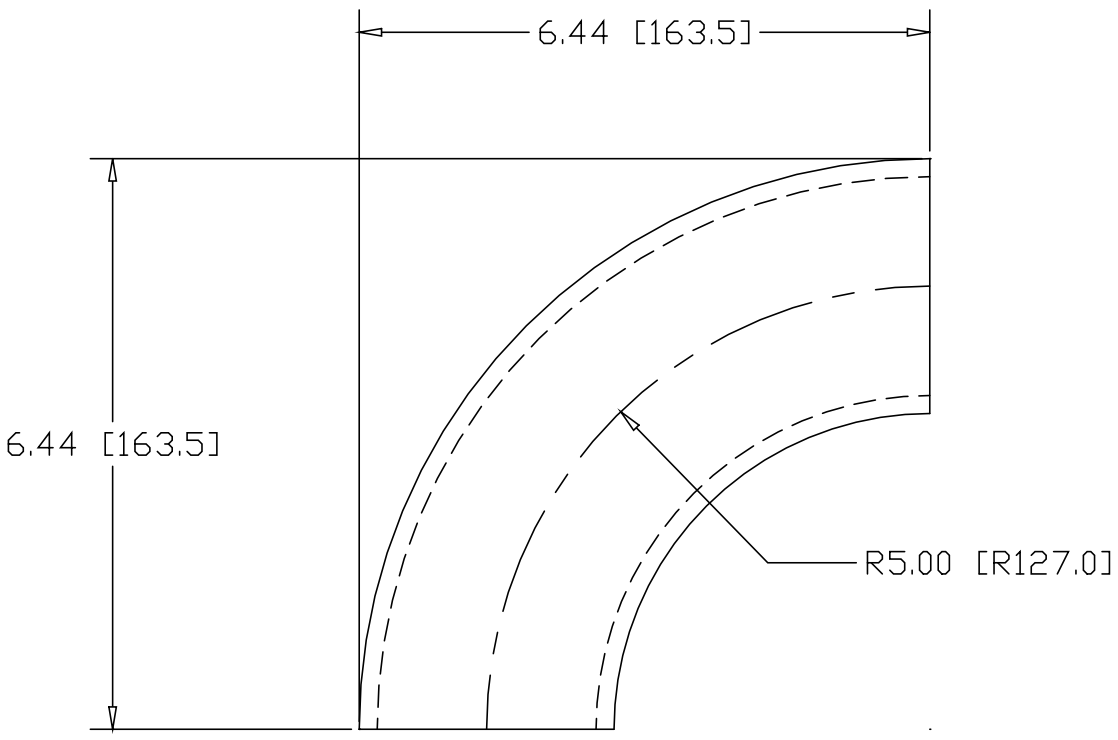

INCHES [MILLIMETERS]

ALTERNATE MATERIAL	PART NUMBER
2-1/2" SCH 40 6063 ALUMINUM PIPE	9603

PART NAME 2-1/2" PIPE SIZE 90° ELL X 5" CLR W/(2) 4" TANGENTS				
MATERIAL 2-1/2" SCH 40 STEEL PIPE				
DATE 9/2/03		THE WAGNER COMPANIES R & B WAGNER, INC. AND J. G. BRAUN CO.		
DRAWN BY RJF				
FINISH MILL				
SIZE A	WEIGHT 3.79 LBS	PART NUMBER 9600	REV	