

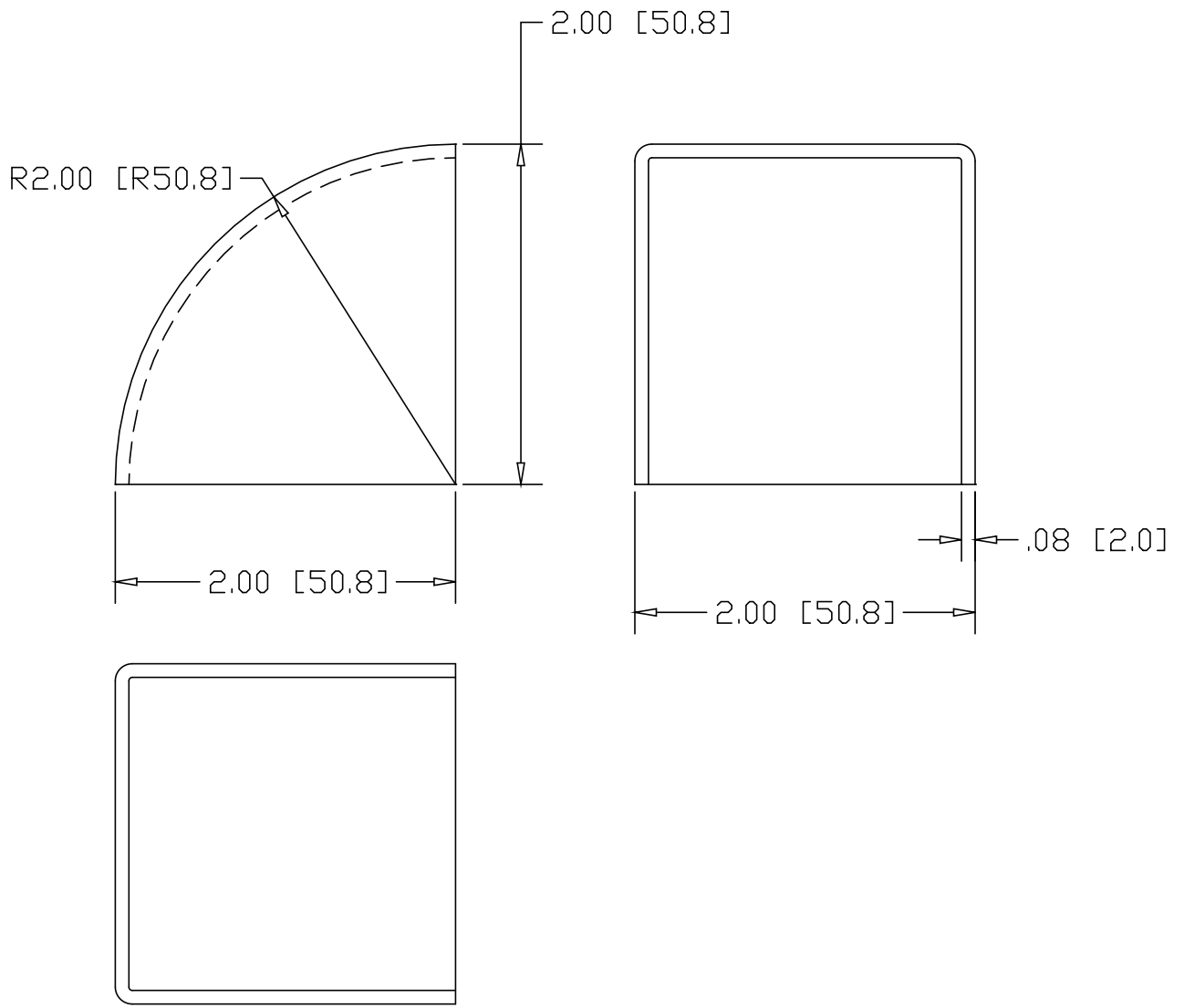

REV
SH
9225
DWG NO

REVISIONS			
REV	DESCRIPTION	DATE	APPROVED



INCHES [MILLIMETERS]

ALTERNATE MATERIAL	PART NUMBER
.080 (3003) ALUMINUM ASTM B209	9226
14 GA. (304) STAINLESS STEEL	9227
.083 (260) BRASS	9228

PART NAME		2" SQUARE TUBE CORNER					
MATERIAL		14 GA. HRP&D STEEL ASTM A569					
DATE	8/26/96		THE WAGNER COMPANIES R & B WAGNER, INC. AND J. G. BRAUN CO.				
DRAWN BY	RJF						
FINISH	MILL						
SIZE	A	WEIGHT	.24 LBS	PART NUMBER	9225	REV	