

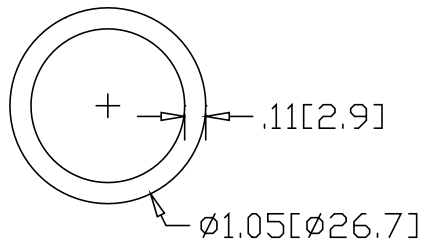

REV  
SH  
155-7  
DWG NO

REVISIONS			
REV	DESCRIPTION	DATE	APPROVED

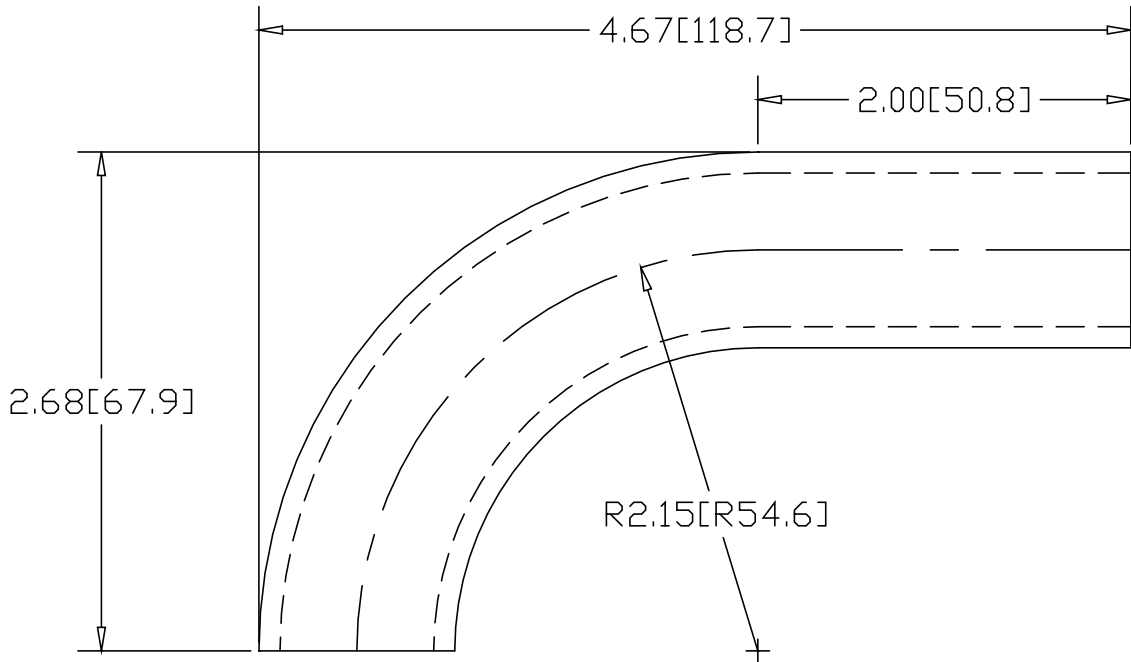

INCHES [MILLIMETERS]

ALTERNATE MATERIAL	PART NUMBER
3/4" SCH 40 (6063) ALUMINUM PIPE	165-1
3/4" SCH 40 (304) STAINLESS STEEL PIPE	175-1

PART NAME 3/4" PIPE SIZE 90° ELL X 1-5/8" I.R. W/(1) 2" TANGENT				
MATERIAL 3/4" SCH 40 A53 STEEL PIPE				
DATE 8/18/95	 <b>R &amp; B WAGNER, INC.</b>			
DRAWN BY RJF				
FINISH MILL	SIZE A	WEIGHT .70 LBS	PART NUMBER 155-7	REV