

REV
SH
2834
DWG NO

REVISIONS			
REV	DESCRIPTION	DATE	APPROVED

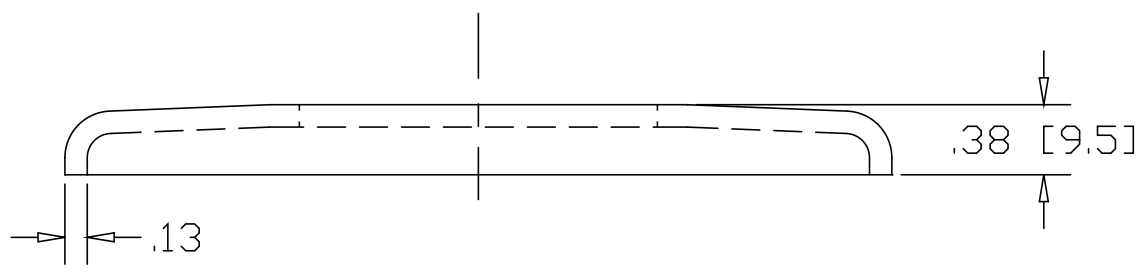
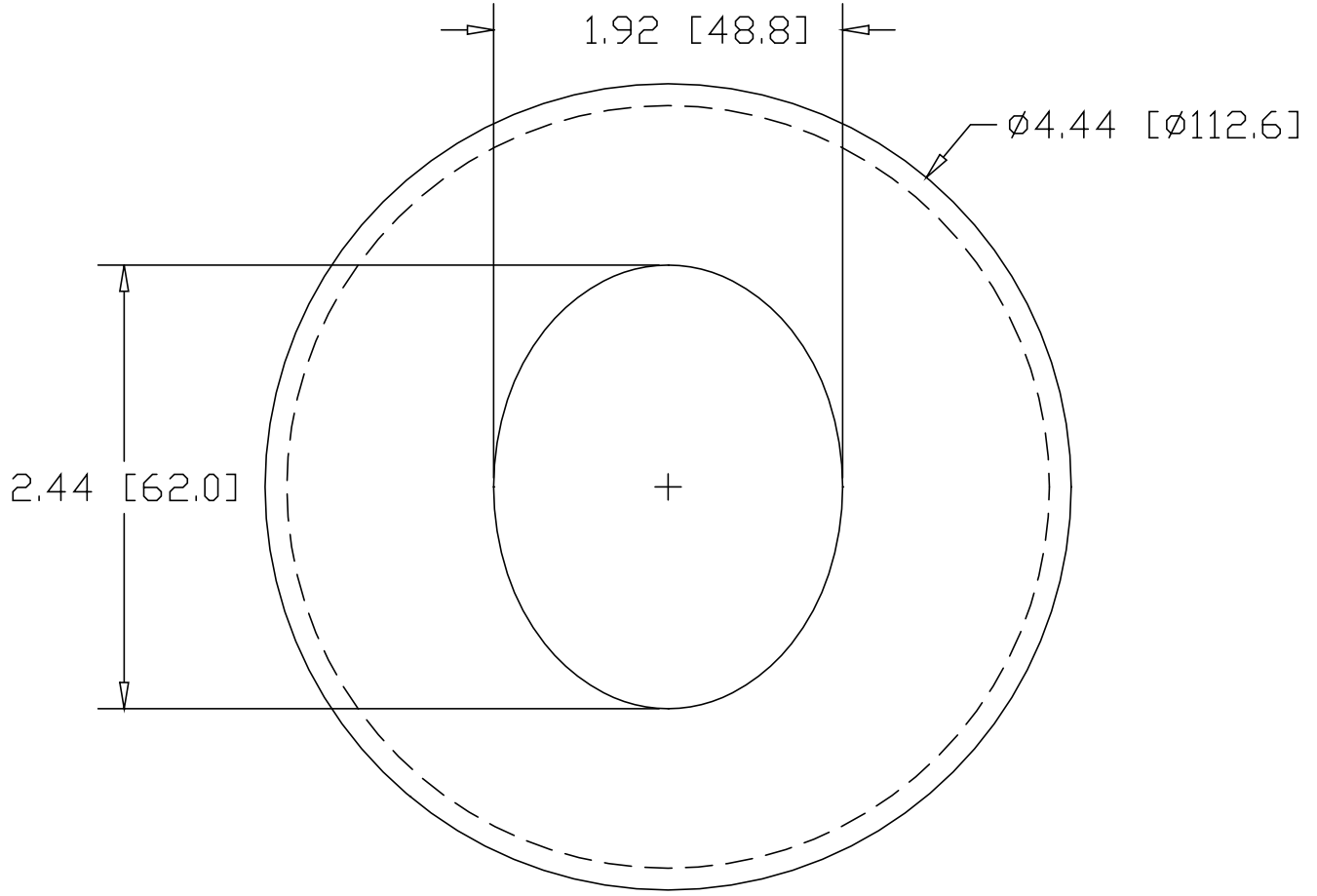

INCHES [MILLIMETERS]

ALTERNATE MATERIAL	PART NUMBER
.125 (3003) ALUMINUM ASTM B209	2874
10 GA. (304) STAINLESS STEEL ASTM A240	2914

PART NAME				1-1/2" PIPE HEAVY FLUSH BASE BEVELED FLANGE	
MATERIAL				10 GA. HRP&D STEEL ASTM A569	
DATE	9/6/94	WAGNER		R & B WAGNER, INC.	
DRAWN BY	RJF				
FINISH	MILL	SIZE	A	WEIGHT	.63 LBS
			PART NUMBER	2834	REV