

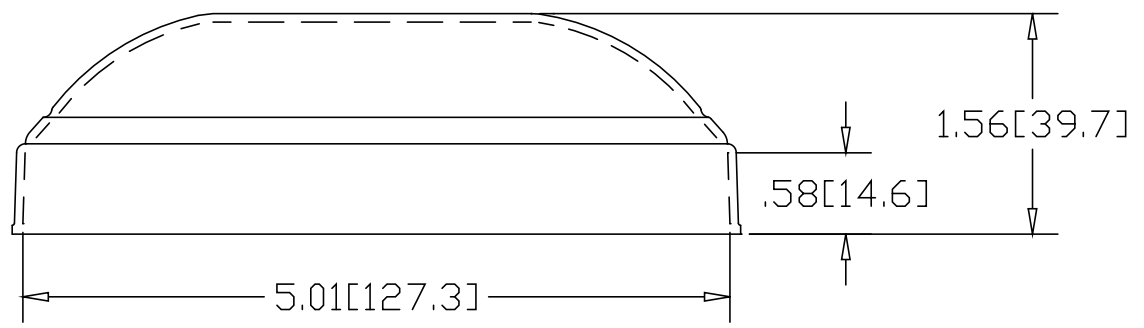

REV
SH
5147
DWG NO

REVISIONS			
REV	DESCRIPTION	DATE	APPROVED

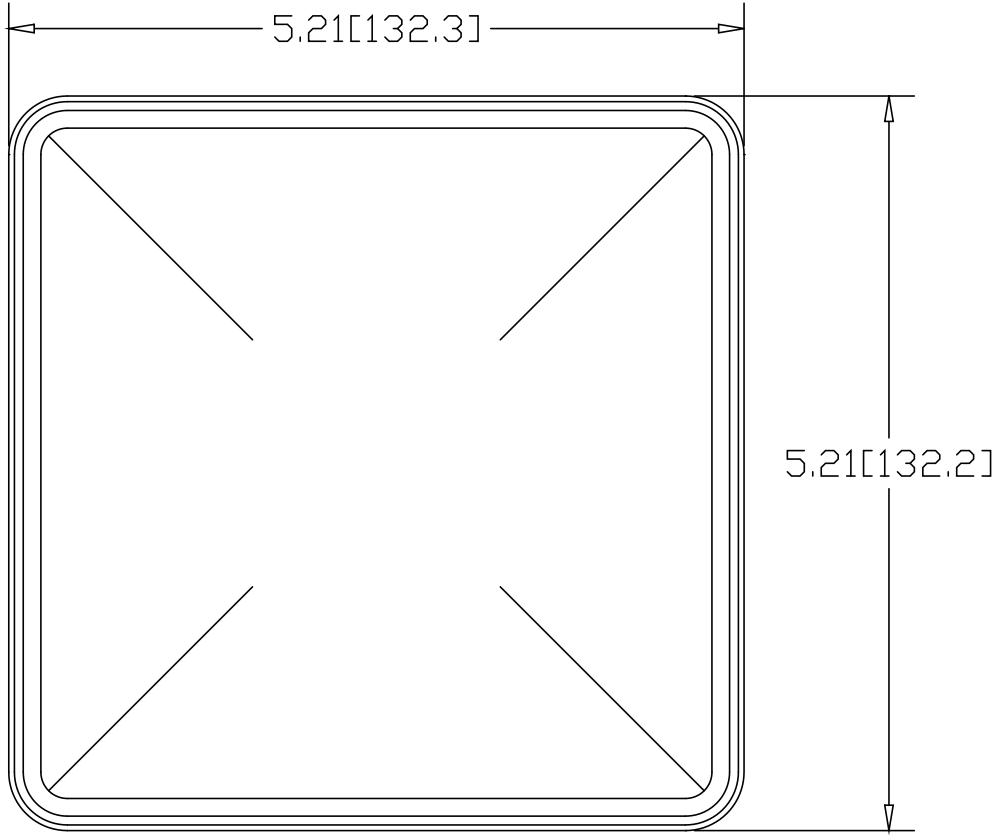

INCHES [MILLIMETERS]

ALTERNATE MATERIAL	PART NUMBER
.050 (3003) ALUMINUM ASTM B209	5147A

PART NAME		5.00" NEWEL POST CAP					
MATERIAL		18 GA. STEEL ASTM A-366					
DATE	10/26/93	 THE WAGNER COMPANIES R & B WAGNER, INC. AND J. G. BRAUN CO.					
DRAWN BY	RJF						
FINISH	MILL						
SIZE	A	WEIGHT	.5 lbs	PART NUMBER	5147	REV	