

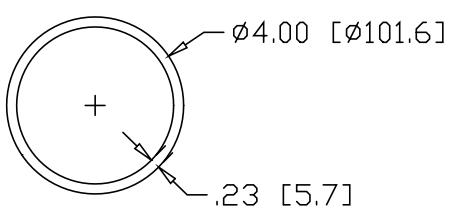

REV  
SH  
90160  
DWG NO

REVISIONS			
REV	DESCRIPTION	DATE	APPROVED

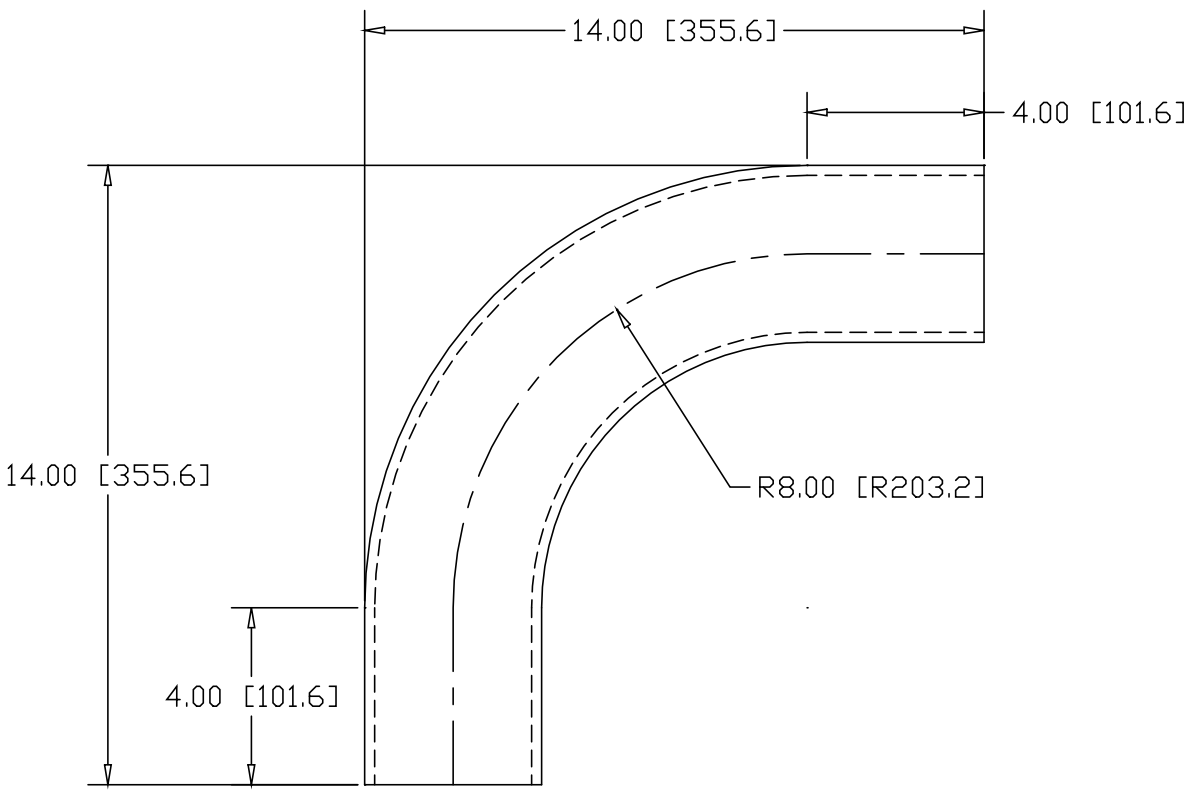

INCHES MILLIMETERS

ALTERNATE MATERIAL	PART NUMBER
3-1/2" SCH 40 6063 ALUMINUM PIPE	91160
3-1/2" SCH 40 (304) STAINLESS STEEL PIPE	92160

PART NAME		3-1/2" SCH 40 8" CLR 90° BEND W/(2) 4" TANGENTS					
MATERIAL		3-1/2" SCH 40 STEEL PIPE A53					
DATE	9-03-03	 <b>THE WAGNER COMPANIES</b> R & B WAGNER, INC. AND J. G. BRAUN CO.					
DRAWN BY	RJF						
FINISH	MILL						
SIZE	A	WEIGHT	15.62 LBS	PART NUMBER	90160	REV	