

REV
SH
2535AT
DWG NO

REVISIONS			
REV	DESCRIPTION	DATE	APPROVED

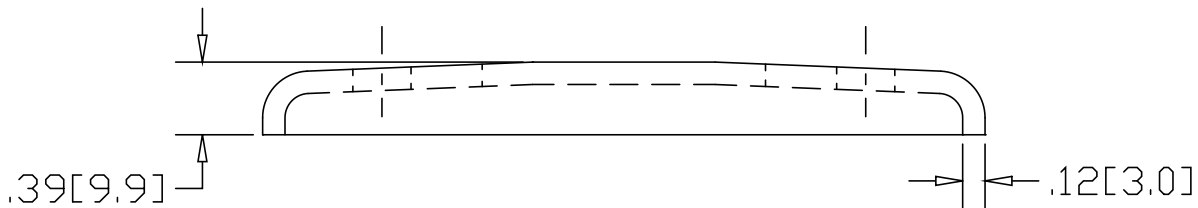
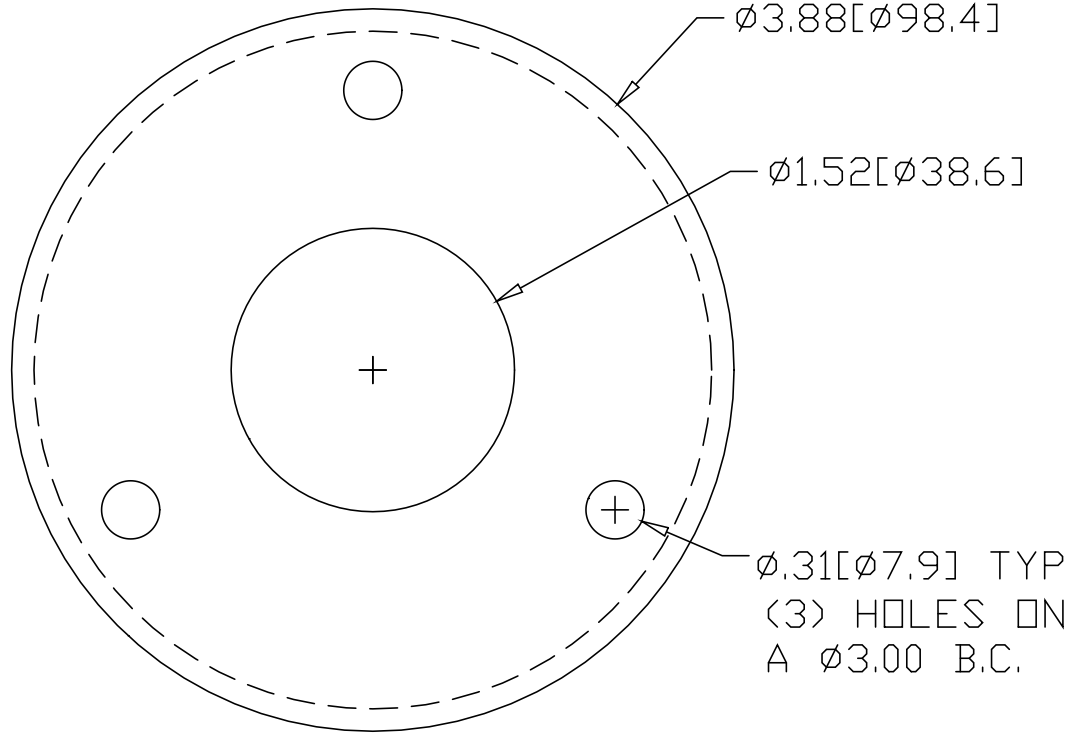

INCHES [MILLIMETERS]

*USE WITH ANCHOR PLATE
 #B1432 IN STEEL
 #PLB1432 ZINC PLATED STEEL
 #B1532 IN STAINLESS STEEL

ALTERNATE MATERIAL	PART NUMBER
.125 (3003) ALUMINUM ASTM B209	2575AT
10 GA. (304) STAINLESS STEEL ASTM A240	2615AT

PART NAME 1.50" OD TUBE HEAVY FLUSH BASE FLANGE W/(3) HOLES			
MATERIAL 10 GA. HRP&O STEEL ASTM A569			
DATE 3/31/99		R & B WAGNER, INC.	
DRAWN BY RJF			
FINISH MILL	SIZE A	WEIGHT .5 LBS	PART NUMBER 2535AT
			REV