

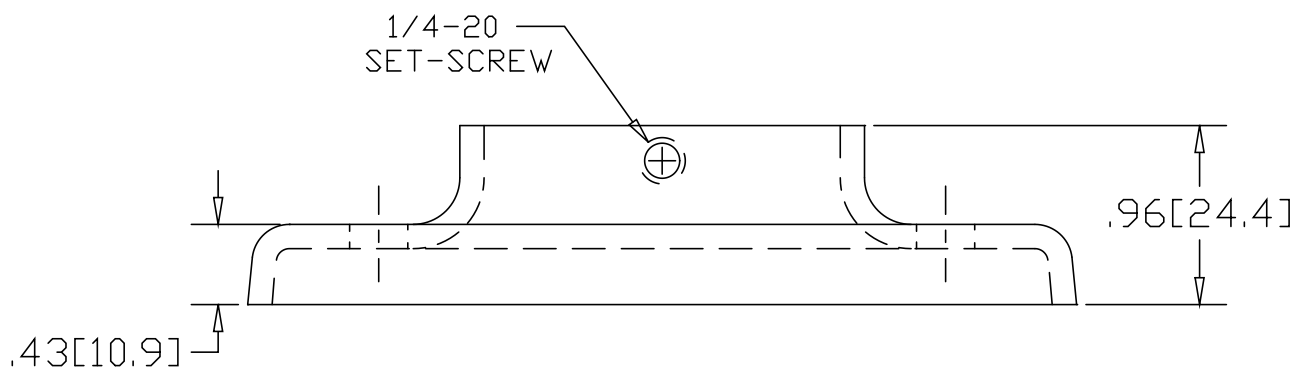

REV
SH
1438A
DWG NO

REVISIONS			
REV	DESCRIPTION	DATE	APPROVED

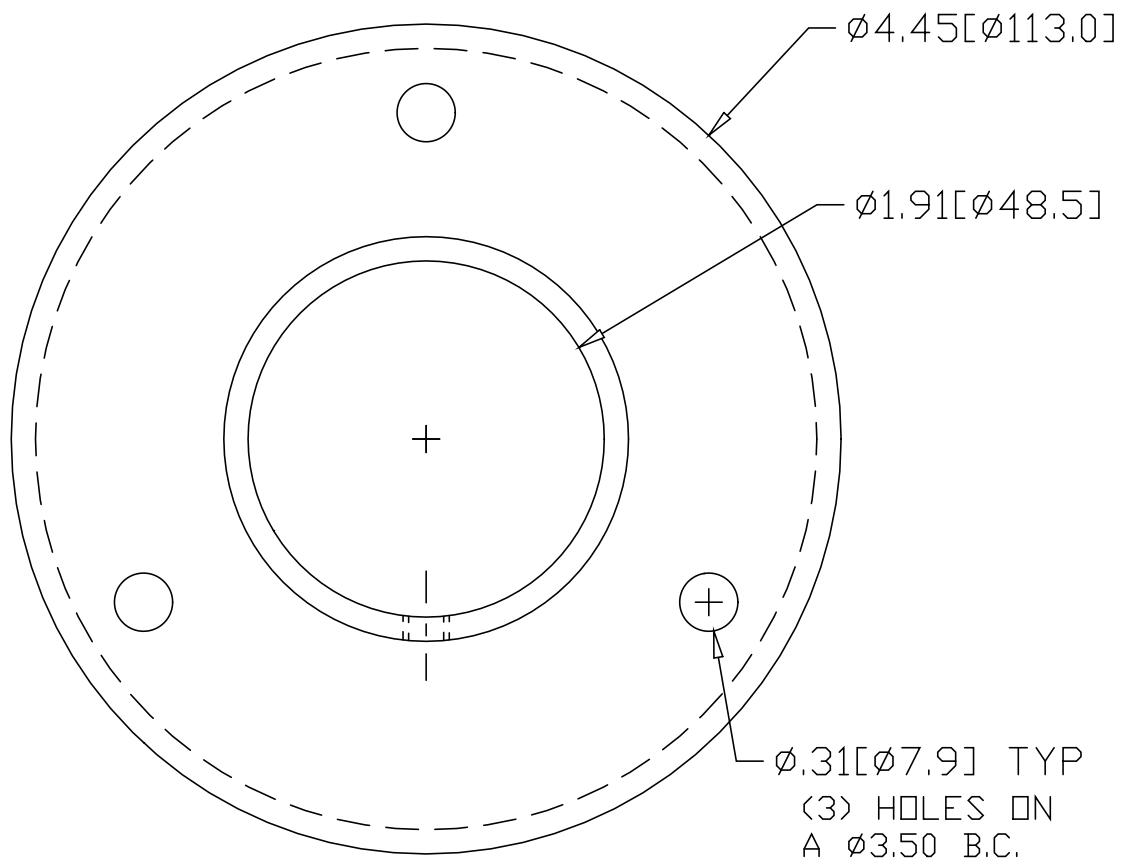

INCHES [MILLIMETERS]

ALTERNATE MATERIAL	PART NUMBER
.125 (3003) ALUMINUM ASTM B209	1478A
10 GA. (304) STAINLESS STEEL ASTM A240	1538A

PART NAME 1-1/2" PIPE HEAVY BASE FLANGE W/(3) HOLES & SET-SCREW			
MATERIAL 10 GA. HRP&D STEEL ASTM A569			
DATE 9/13/94		R & B WAGNER, INC.	
DRAWN BY RJF		FINISH MILL	SIZE A
		PART NUMBER 1438A	REV