

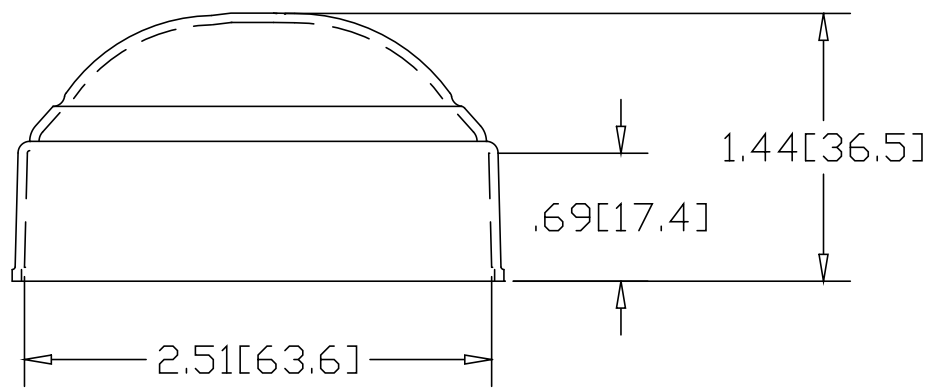

REV  
SH  
5104  
DWG NO

REVISIONS			
REV	DESCRIPTION	DATE	APPROVED

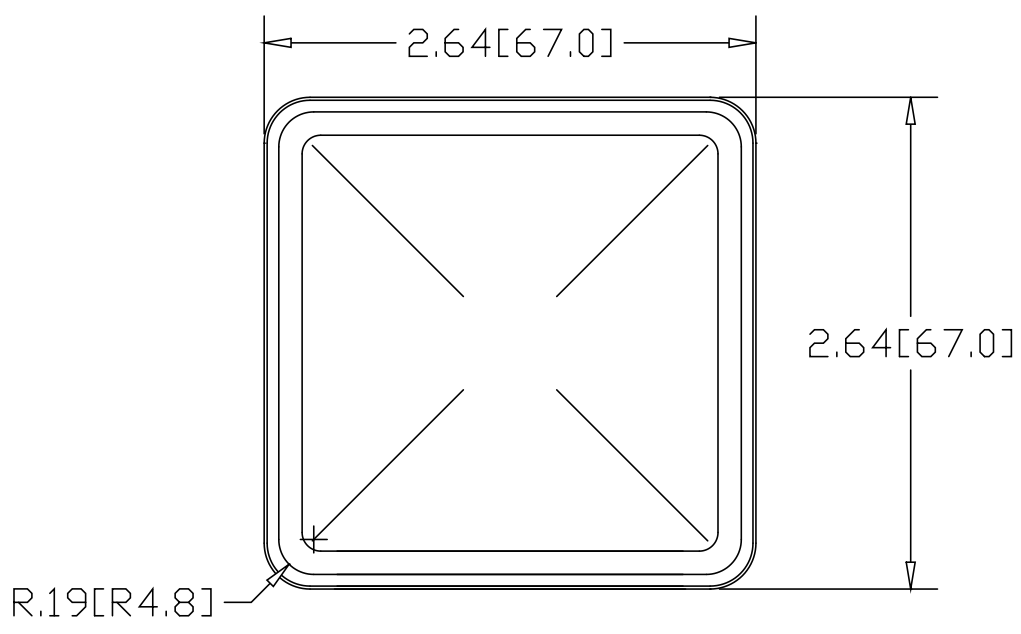

INCHES [MILLIMETERS]

ALTERNATE MATERIAL	PART NUMBER
.050 (3003) ALUMINUM ASTM B209	5105
18 GA. (304) STAINLESS STEEL ASTM A240	5111

PART NAME		2.50" SQUARE NEWEL POST CAP					
MATERIAL		18 GA. CR STEEL ASTM A366					
DATE	2/24/93	 <b>THE WAGNER COMPANIES</b> R & B WAGNER, INC. AND J. G. BRAUN CO.					
DRAWN BY	RJF						
FINISH	HRP&0						
SIZE	A	WEIGHT	.20 LBS	PART NUMBER	5104	REV	