

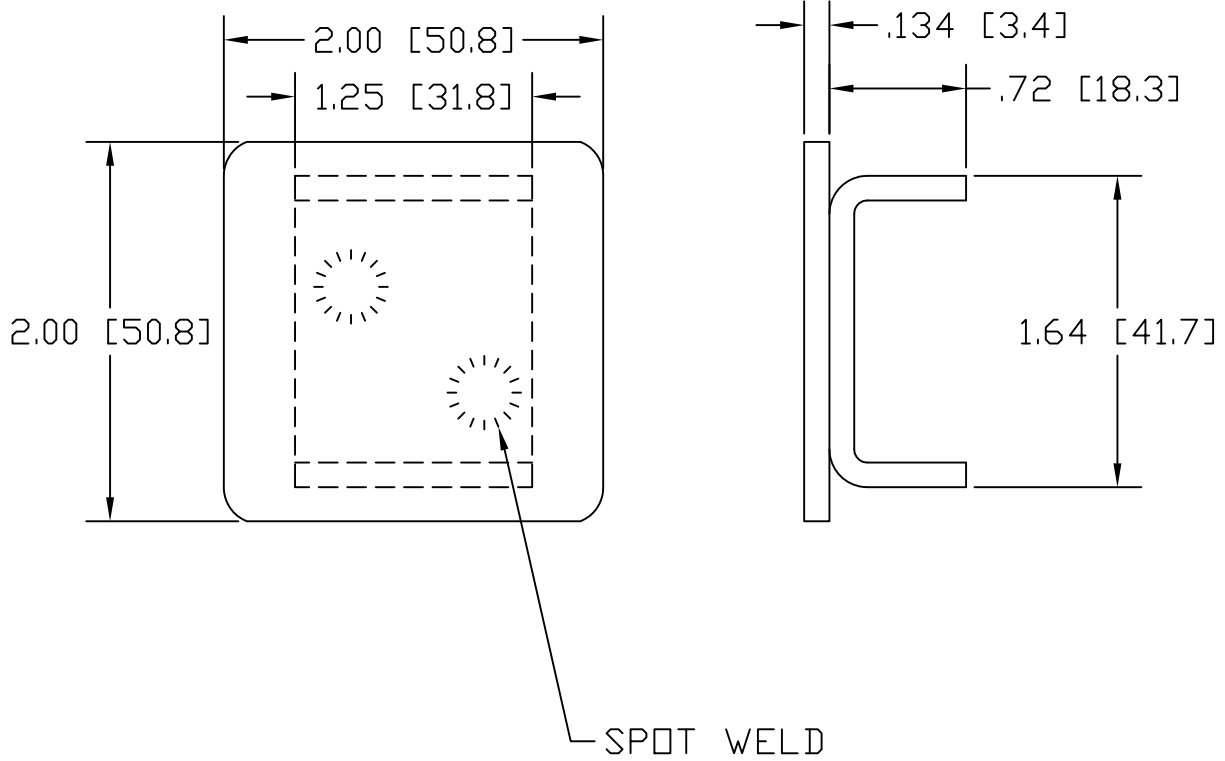

REV B
SH
3202-188
DWG NO

REVISIONS			
REV	DESCRIPTION	DATE	APPROVED
A	MATERIAL WAS 7 GA.	04/12/12	RJF
B	YOKE WIDTH 1.25 WAS 1.48	09/19/16	RJF



INCHES [MILLIMETERS]

PART NAME		2.00" SQUARE X .188 WALL DRIVE-ON CAP			
MATERIAL		10 GA. HRP&D STEEL ASTM A569			
DATE	6/3/98	 THE WAGNER COMPANIES R & B WAGNER, INC. AND J. G. BRAUN CO.			
DRAWN BY	RJF				
FINISH	MILL	SIZE	WEIGHT	PART NUMBER	REV
		A	.33 LBS	3202-188	B