

REV  
SH  
8041  
DWG NO

REVISIONS			
REV	DESCRIPTION	DATE	APPROVED

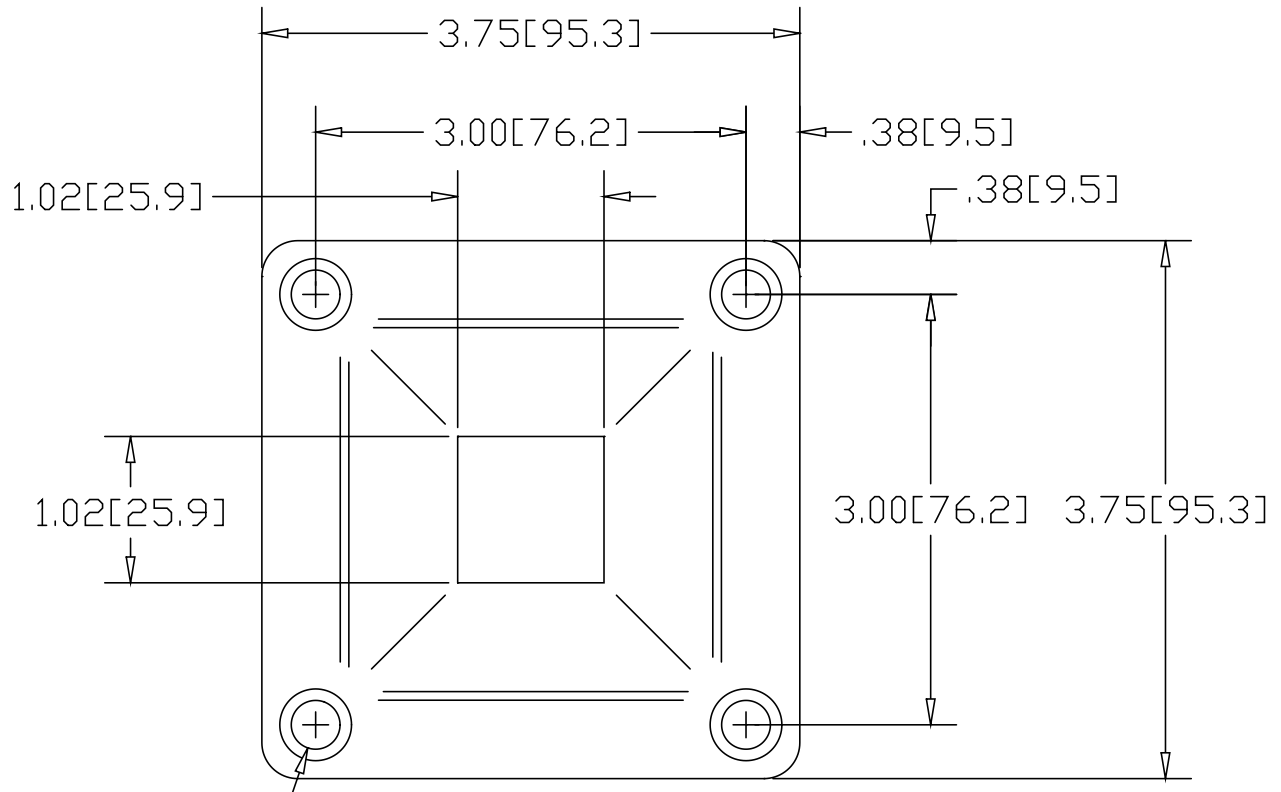

Ø.34 [Ø8.6] TYP  
W/C SINK

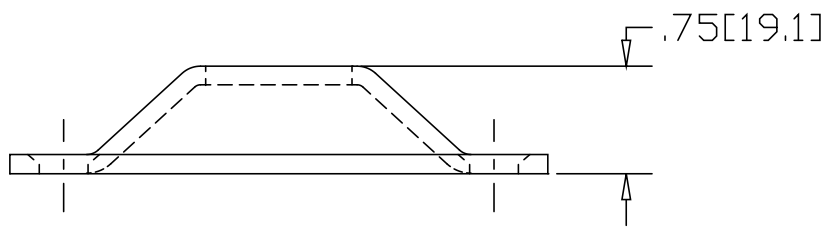

\*USE WITH ANCHOR PLATE  
#8057 IN STEEL  
#8058 IN ALUMINUM

INCHES [MILLIMETERS]

ALTERNATE MATERIAL	PART NUMBER
.125 (3003) ALUMINUM ASTM B209	8042

PART NAME 1" SQUARE TUBE FLANGE WITH (4) HOLES			
MATERIAL 10 GA. HRP&D STEEL ASTM A569			
DATE 7/24/96	 <b>R &amp; B WAGNER, INC.</b>		
DRAWN BY RJF			
FINISH MILL	SIZE A	WEIGHT .53 LBS	PART NUMBER 8041
			REV