

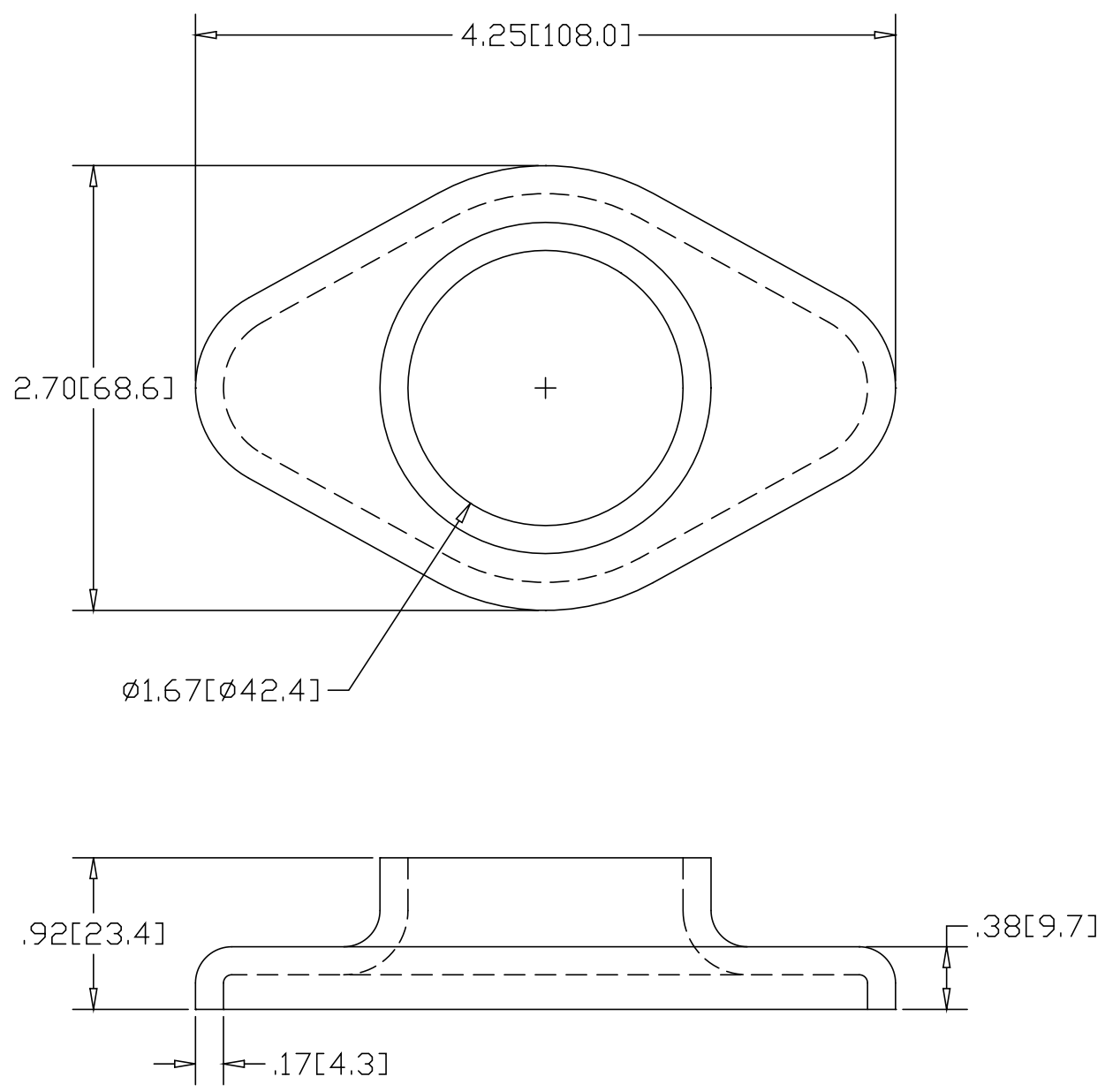

REV  
SH  
4910  
DWG NO

| REVISIONS |             |      |          |
|-----------|-------------|------|----------|
| REV       | DESCRIPTION | DATE | APPROVED |



INCHES [MILLIMETERS]

| ALTERNATE MATERIAL                    | PART NUMBER |
|---------------------------------------|-------------|
| .190 (3003) ALUMINUM ASTM B209        | 4940        |
| 7 GA. (304) STAINLESS STEEL ASTM A240 | 4970        |

|  |   |                    |        |
|--|---|--------------------|--------|
| PART NAME 1-1/4" PIPE SIZE TAPERED HEAVY BASE FLANGE |   |                    |        |
| MATERIAL 7 GA. HRP&D STEEL ASTM A569                 |   |                    |        |
| DATE 5/22/95   |  | R & B WAGNER, INC. |        |
| DRAWN BY RJF   |   | FINISH MILL        | SIZE A |
|  |   | PART NUMBER 4910   | REV    |