

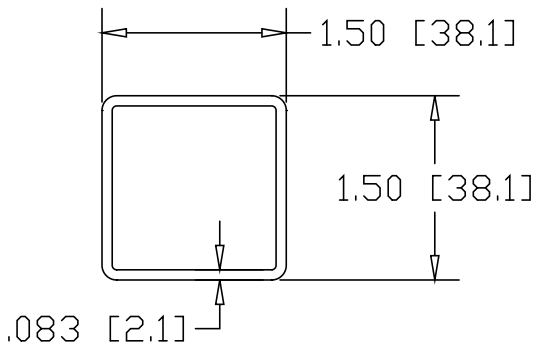

REV
SH
6362
DWG NO

REVISIONS			
REV	DESCRIPTION	DATE	APPROVED

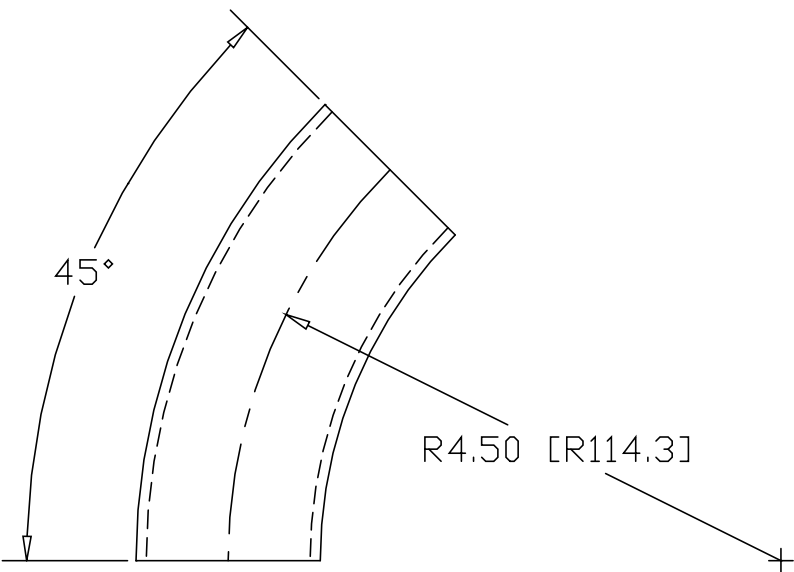

INCHES [MILLIMETERS]

PART NAME		1.50" SQUARE STEEL 45° X 4.50" CLR ELL					
MATERIAL		1.50" X .083W SQUARE STEEL TUBE					
DATE	10/3/00		THE WAGNER COMPANIES R & B WAGNER, INC. AND J. G. BRAUN CO.				
DRAWN BY	RJF						
FINISH	MILL						
SIZE	A	WEIGHT	.48 LBS	PART NUMBER	6362	REV	