

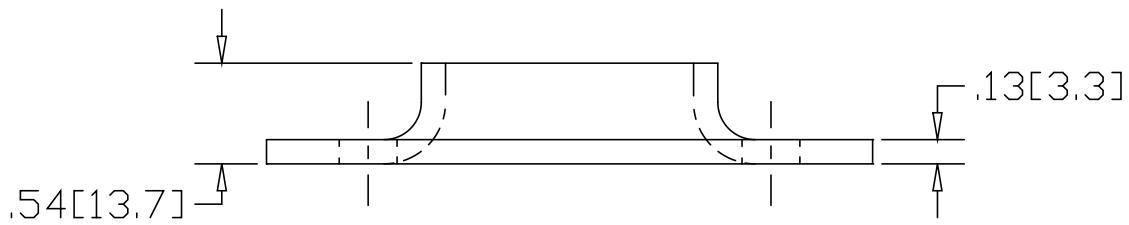

REV
SH
627AT
DWG NO

REVISIONS			
REV	DESCRIPTION	DATE	APPROVED

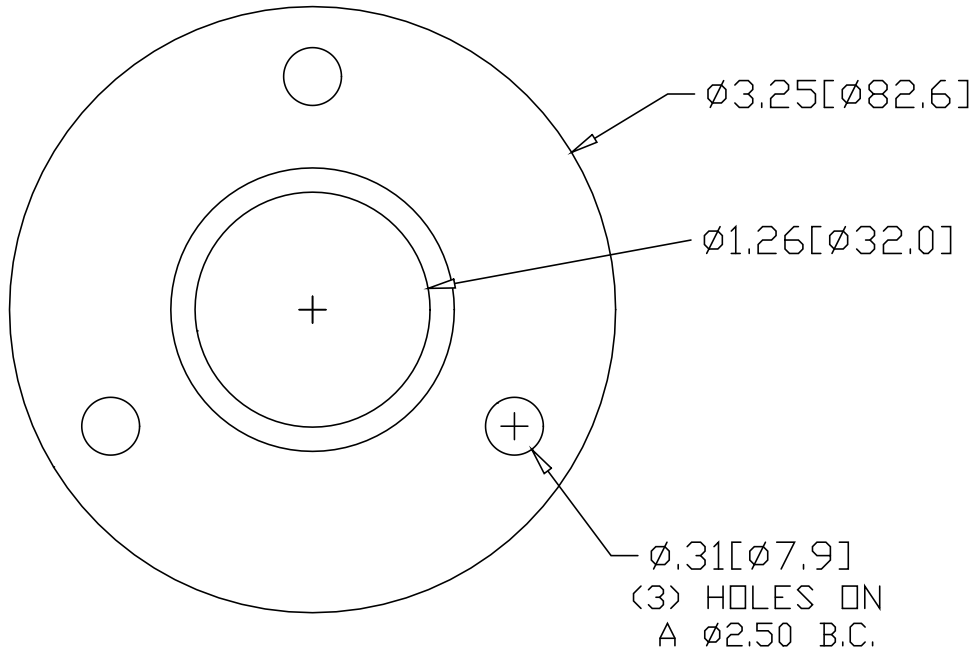

INCHES [MILLIMETERS]

ALTERNATE MATERIAL	PART NUMBER
.125 (3003) ALUMINUM ASTM B209	667AT
10 GA. (304) STAINLESS STEEL ASTM A240	707AT

PART NAME 1-1/4" O.D. TUBE FLAT BASE FLANGE W/(3) HOLES			
MATERIAL 10 GA. HRP&O STEEL ASTM A-569			
DATE 1/11/99		R & B WAGNER, INC.	
DRAWN BY RJF		SIZE A	WEIGHT .3 LBS
FINISH MILL			REV