

DWG NO 1033T

REV

SH

REVISIONS

REV	DESCRIPTION	DATE	APPROVED
-----	-------------	------	----------

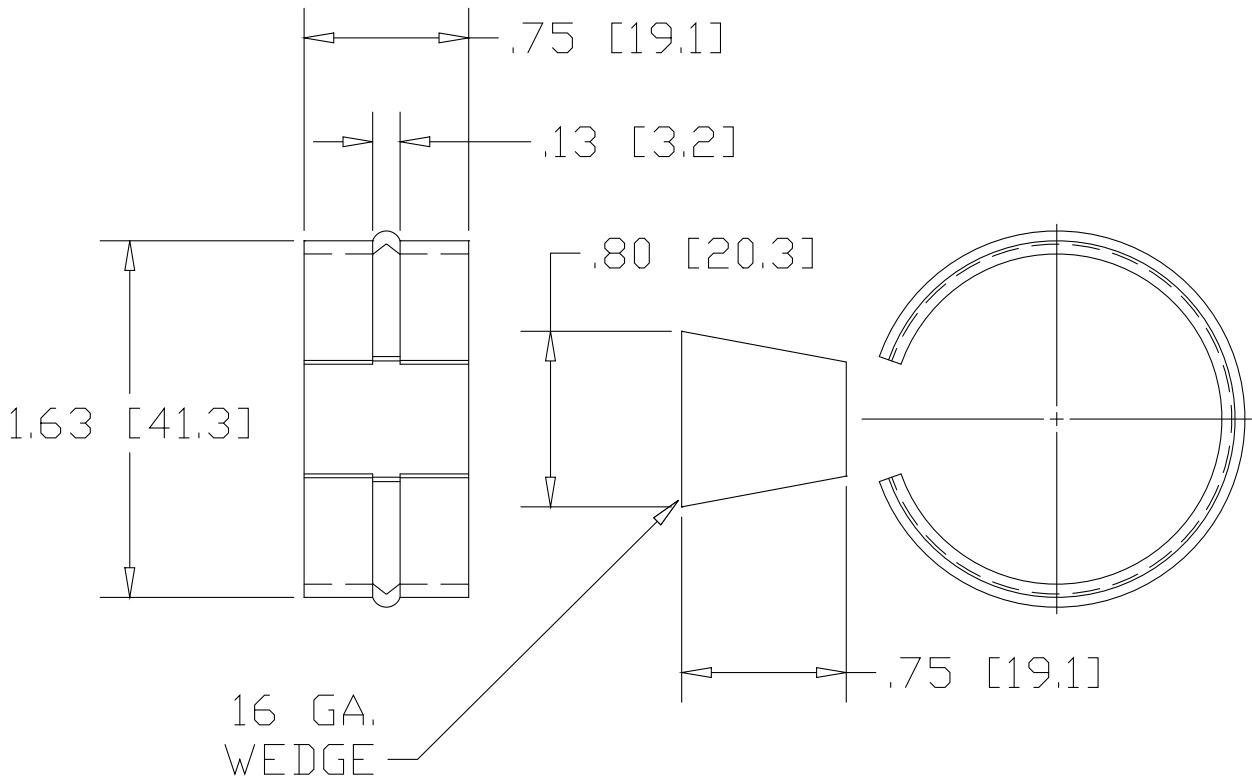
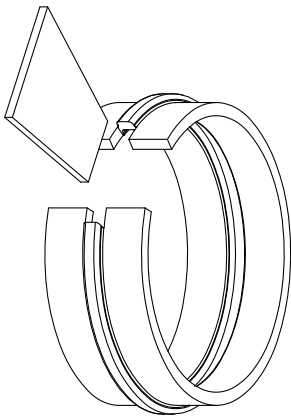

INCHES [MILLIMETERS]

ALTERNATE MATERIAL	PART NUMBER
.063 (3003) ALUMINUM ASTM B209	1034T
.0595 (304) STAINLESS STEEL ASTM A240	1035T

PART NAME 2.00" OD .120W TUBE WEDGE-LOCK WELDING CONNECTOR				
MATERIAL 16 GA. (.063) HRP&D STEEL ASTM A569				
DATE 10/10/01		THE WAGNER COMPANIES R & B WAGNER, INC. AND J. G. BRAUN CO.		
DRAWN BY JAH				
FINISH MILL	SIZE A	WEIGHT .05 LBS	PART NUMBER 1033T	REV