

REVISIONS			
REV	DESCRIPTION	DATE	APPROVED

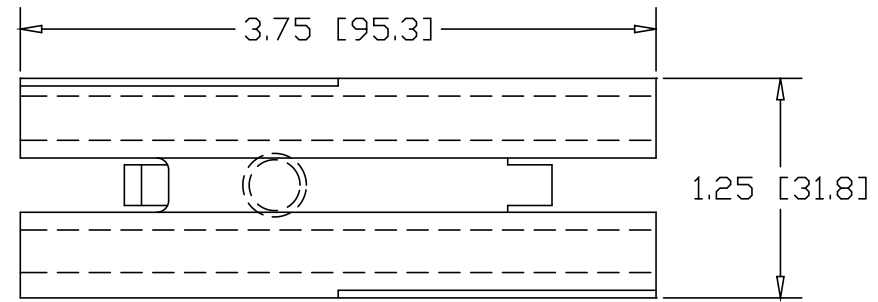

1.50" O.D. X .120W TUBE

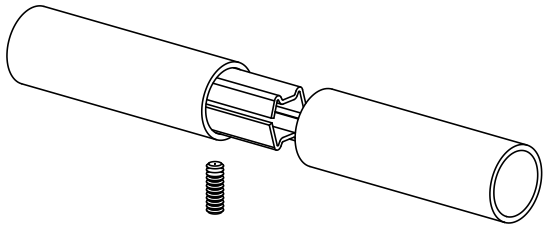
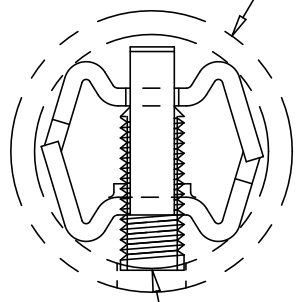

3/8-16 X 1" SET-SCREW

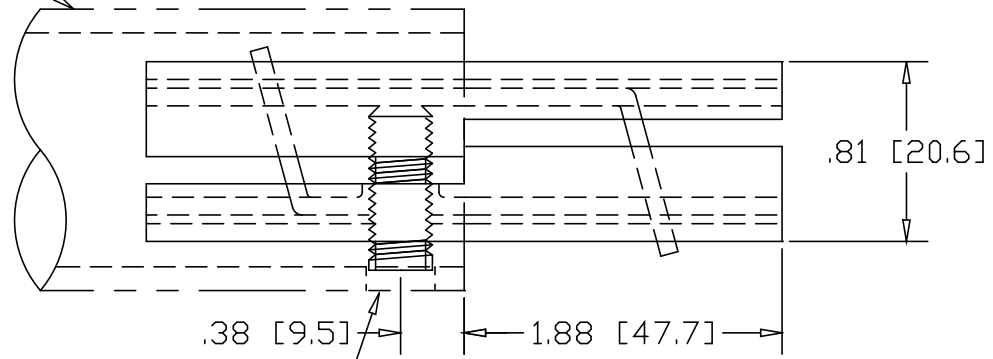

DRILL ϕ .406 HOLE
.38" IN FROM END

INCHES [MILLIMETERS]

ALTERNATE MATERIAL	PART NO.
12 GA. STEEL HOT DIP GALVANIZED	G3326-2
12 GAUGE STEEL ZINC PLATED	PL3326-2
.090 (3003) ALUMINUM ASTM B209	3327-8
.090 (304) STAINLESS STEEL ASTM A240	3329-8

PART NAME		1.50" O.D. .120W TUBE SINGLE-LOCK SPLICE-LOCK		
MATERIAL		12 GAUGE HRP&O STEEL ASTM A569		
DATE	11/7/95	 THE WAGNER COMPANIES R & B WAGNER, INC. AND J. G. BRAUN CO.		
DRAWN BY	RJF		SIZE	WEIGHT
FINISH	MILL		A	.43 LBS
		PART NUMBER	3326-2	REV