

REV
SH
4911
DWG NO

REVISIONS			
REV	DESCRIPTION	DATE	APPROVED

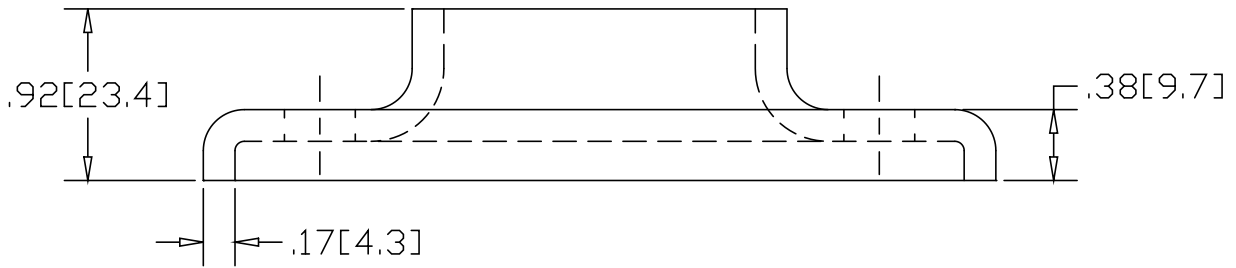
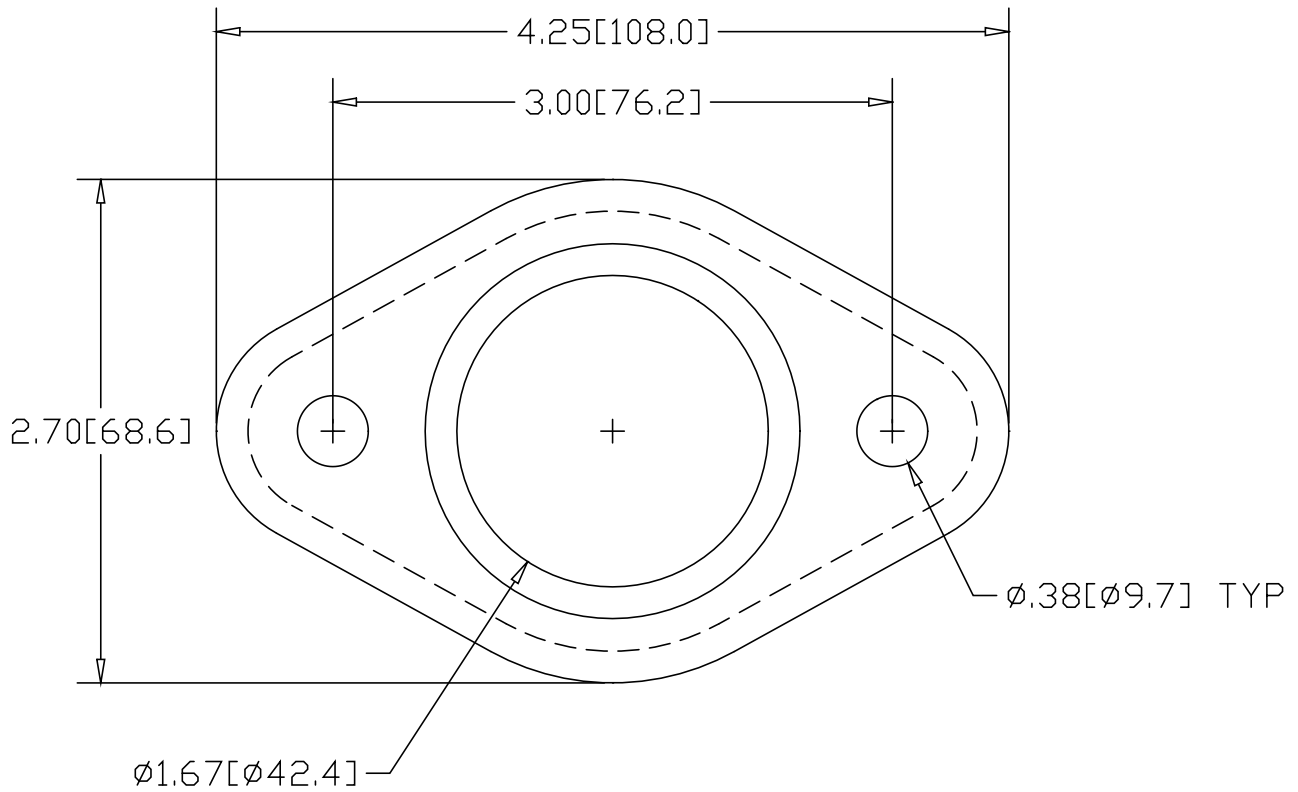

* USE WITH ANCHOR PLATE
 #4914 IN STEEL
 #4944 IN ALUMINUM
 #4974 IN STAINLESS

INCHES [MILLIMETERS]

ALTERNATE MATERIAL	PART NUMBER
.190 (3003) ALUMINUM ASTM B209	4941
7 GA. (304) STAINLESS STEEL ASTM A240	4971

PART NAME 1-1/4" PIPE SIZE TAPERED HEAVY BASE FLANGE W/(2) HOLES				
MATERIAL 7 GA. HRP&D STEEL ASTM A569				
DATE 5/22/95	 R & B WAGNER, INC.			
DRAWN BY RJF				
FINISH MILL	SIZE A	WEIGHT .41 LBS	PART NUMBER 4911	REV