

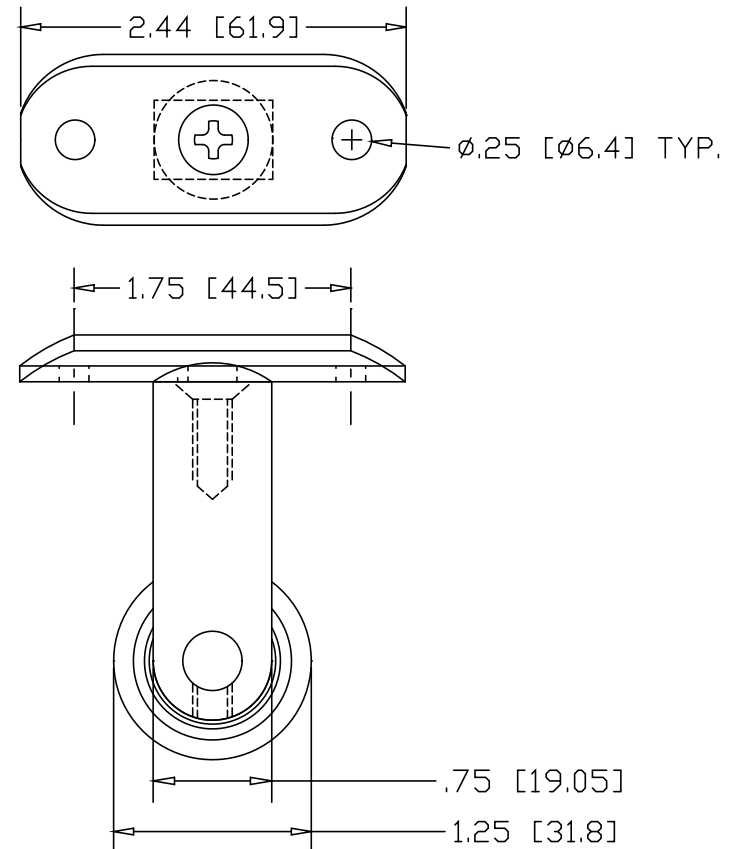

REVISIONS			
REV	DESCRIPTION	DATE	APPROVED
1	REMOVED STEP IN RS253	09/23/10	PWH

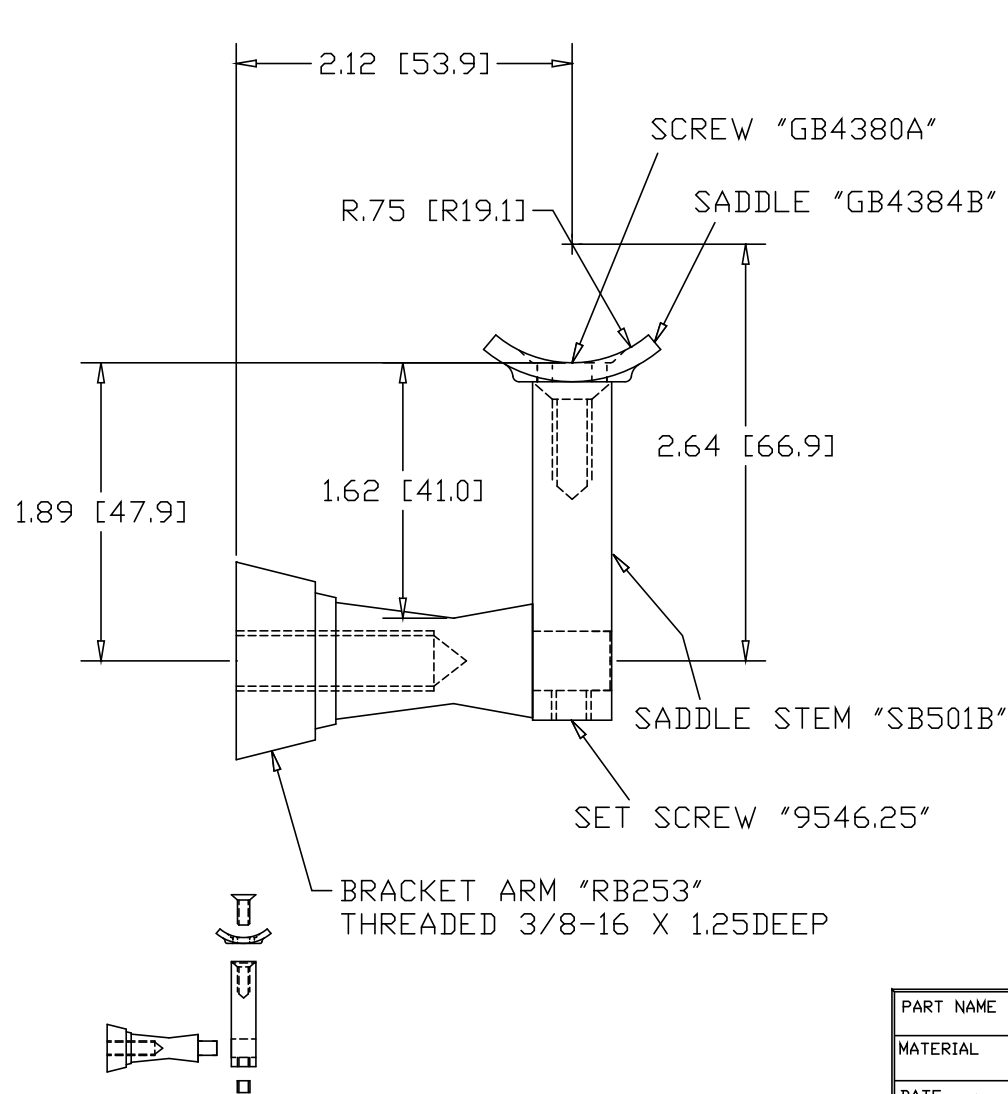

INCHES [MILLIMETERS]

EXPLODED VIEW

PART NAME		MACHINED BRASS BRACKET, POST MOUNT ASSEMBLY	
MATERIAL		360 BRASS	
DATE	1/24/07	 <b>THE WAGNER COMPANIES</b> R & B WAGNER, INC. AND J. G. BRAUN CO.	
DRAWN BY	RDC		
FINISH	#4 SATIN	SIZE	A
		WEIGHT	
		PART NUMBER	MB4252P
		REV	1