

2



1

PARTS LIST

ITEM	QTY	PART NUMBER	DESCRIPTION
1	1	GR2LL5075HCB-10	Shoe Moulding, Aluminum, Level lock Plus, For .5 to .75 Glass, 2.75 Wide, 3.75 High, 10 Foot Lengths, No Holes, Mill Finish
2	1	LL5817	Level Lock Plus, Mechanism 10 Pack, for 5/8" Nominal Glass, .569-.726"
3	1	GR9LL1250	Shoe Isolator, Level Lock +, HDPE, 0.125 x 0.50 x 2.00, 10 pack

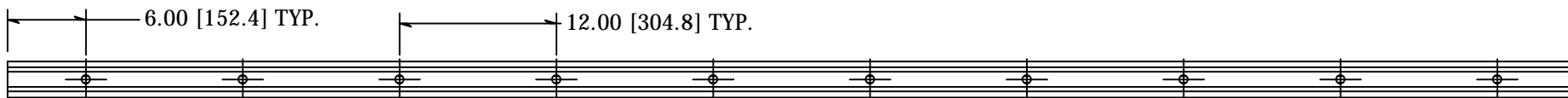
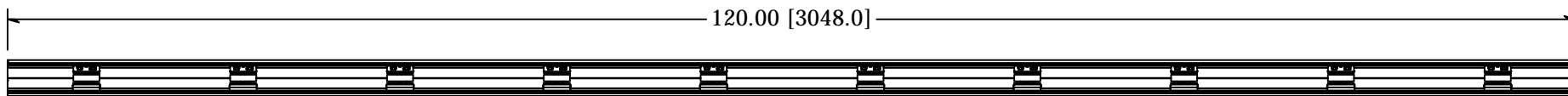
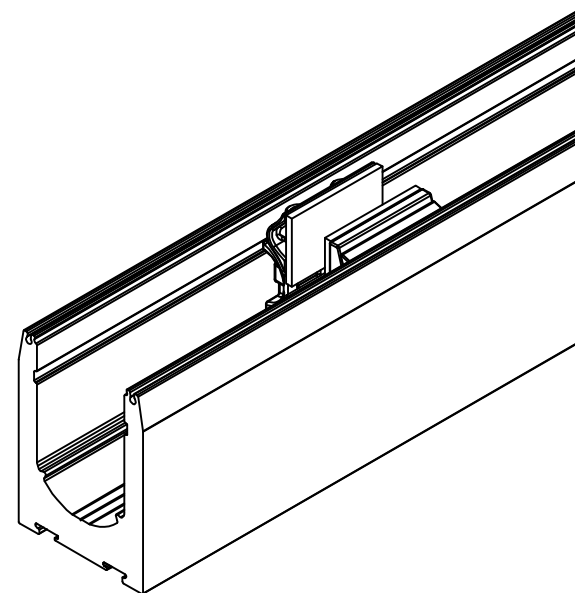
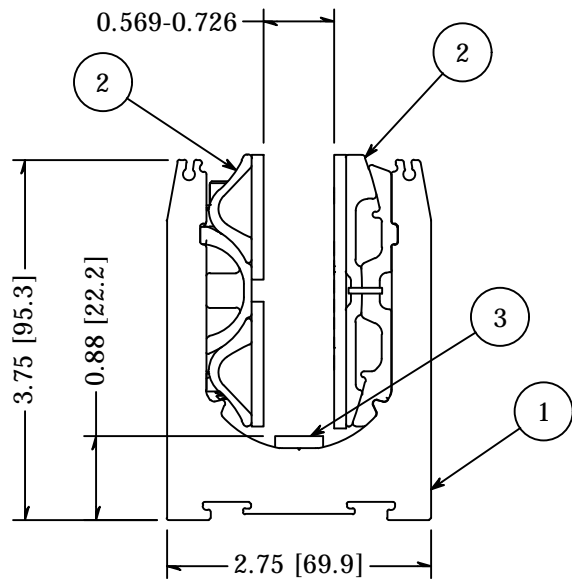

TOLERANCE X.XX +/- 0.01 X.XXX +/- 0.005 Angle +/- 0.5 Unless Otherwise Specified	CUT LENGTH:	FINISH:	DESCRIPTION:	
		MILL	Level Lock Plus, Sales kit, for 5/8", 15mm - 17mm glass, 10ft shoe HCB, W/ Mechanisms	
	DEVELOPED LENGTH:	WEIGHT:	MATERIAL:	MATERIAL DESC:
	10FT	N/A	DATE: 4/8/2021	REV: 1
TOOL NUMBER:			DRAWN BY: A. Seeboth	10600 W Brown Deer Rd Milwaukee, WI 53224 COLLABORATIVE METALWORKS http://www.wagnercompanies.com/
			PART NUMBER: LL5817KIT10	

2



1

B

B

A

A