

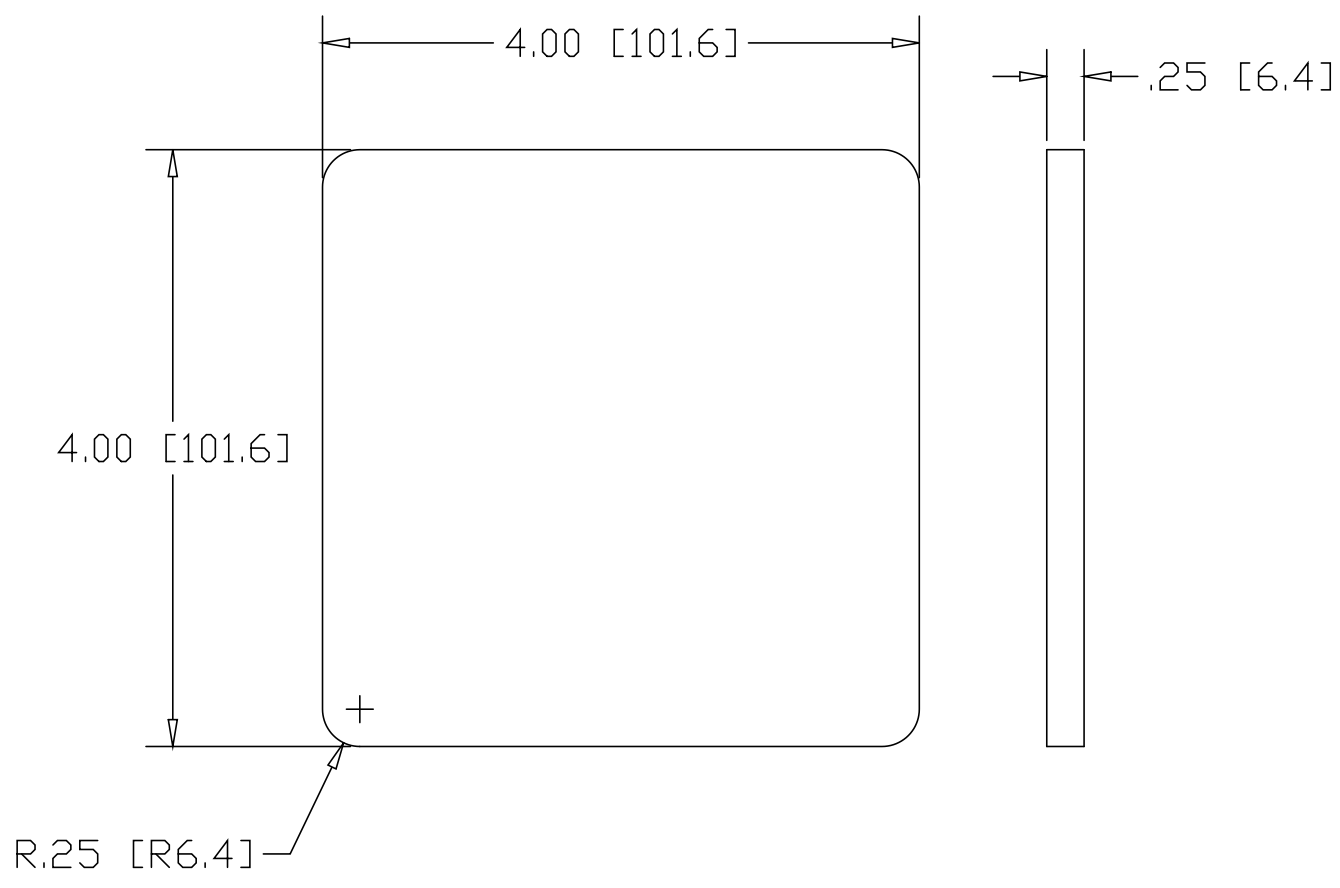

REV
SH
D480
DWG NO

REVISIONS			
REV	DESCRIPTION	DATE	APPROVED



INCHES [MILLIMETERS]

ALTERNATE MATERIAL	PART NUMBER
.250 (3003) ALUMINUM ASTM B209	D481
.18 (304) STAINLESS STEEL ASTM A240	D482
.250 (260) BRASS ASTM B19,B36	D483

PART NAME 4" SQUARE PLATE WITH RADIUS CORNERS			
MATERIAL .250 HRP&D STEEL ASTM A569			
DATE 11/20/98		THE WAGNER COMPANIES R & B WAGNER, INC. AND J. G. BRAUN CO.	
DRAWN BY RJF			
FINISH MILL			
SIZE A	WEIGHT 1.13 LBS	PART NUMBER D480	REV