

REV
SH
2512
DWG NO

REVISIONS			
REV	DESCRIPTION	DATE	APPROVED

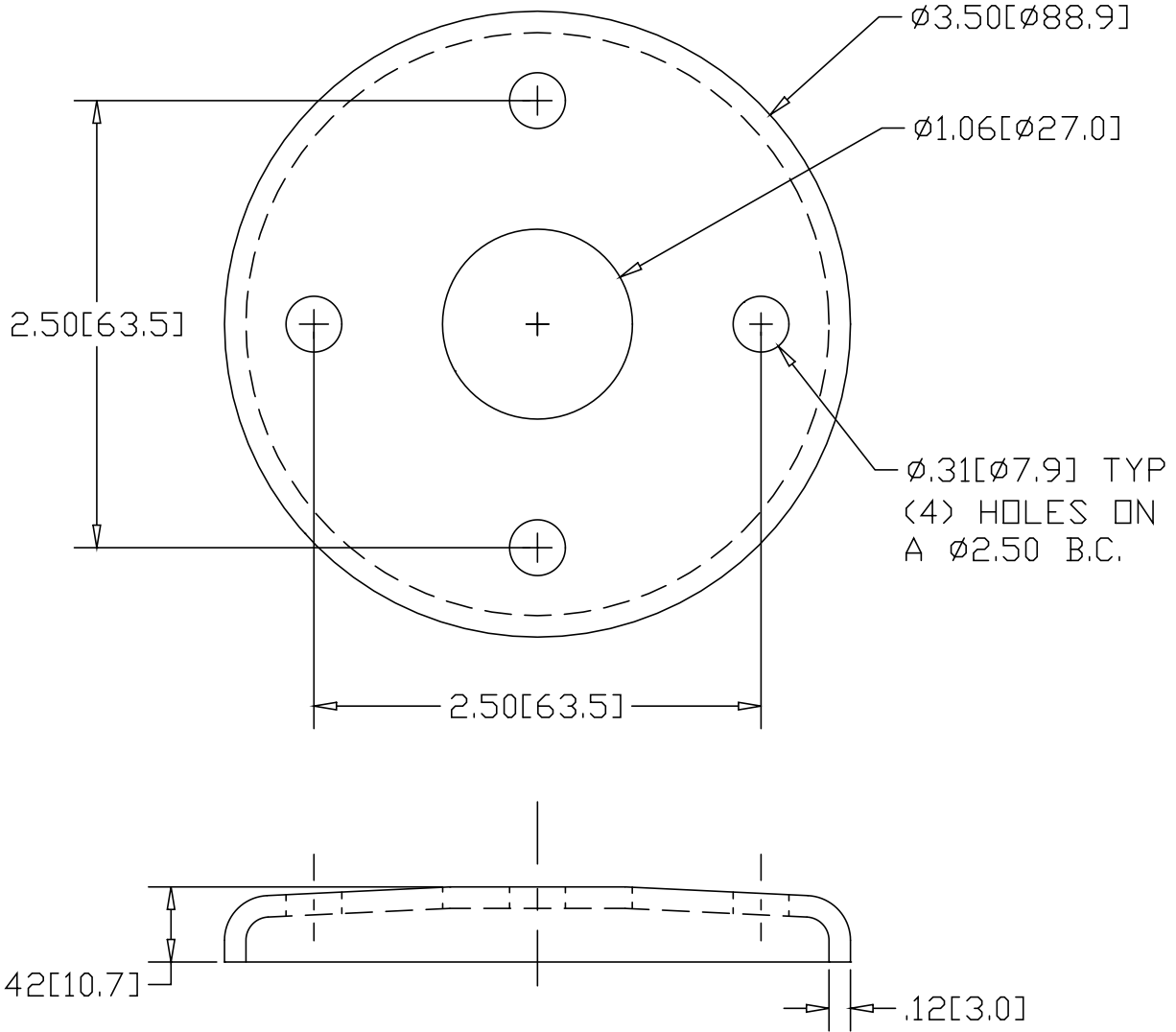

INCHES [MILLIMETERS]

*USE WITH ANCHOR PLATE
#B1416 IN STEEL
#PLB1416 ZINC PLATED STEEL
#B1516 IN STAINLESS

ALTERNATE MATERIAL	PART NUMBER
.125 (3003) ALUMINUM ASTM B209	2552
10 GA. (304) STAINLESS STEEL ASTM A240	2592

PART NAME 3/4" PIPE HEAVY FLUSH BASE FLANGE W/(4) HOLES			
MATERIAL 10 GA. HRP&D STEEL ASTM A569			
DATE 3/31/99		R & B WAGNER, INC.	
DRAWN BY RJF		FINISH MILL	SIZE A
PART NUMBER 2512		REV	