

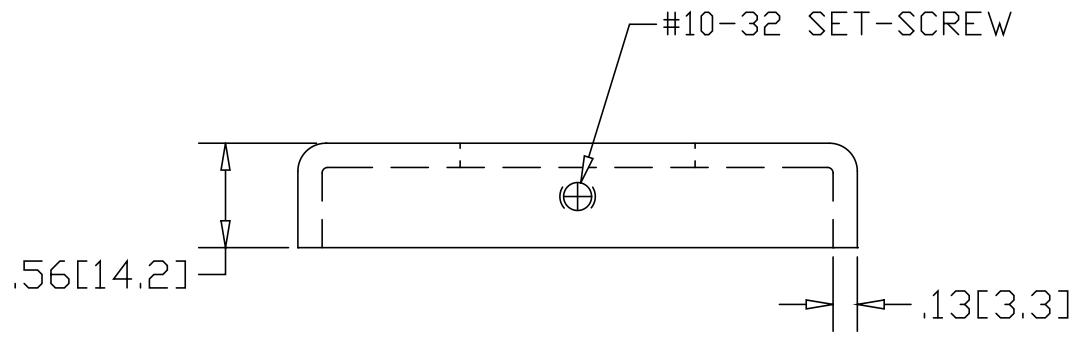

REV
SH
8718
DWG NO

REVISIONS			
REV	DESCRIPTION	DATE	APPROVED

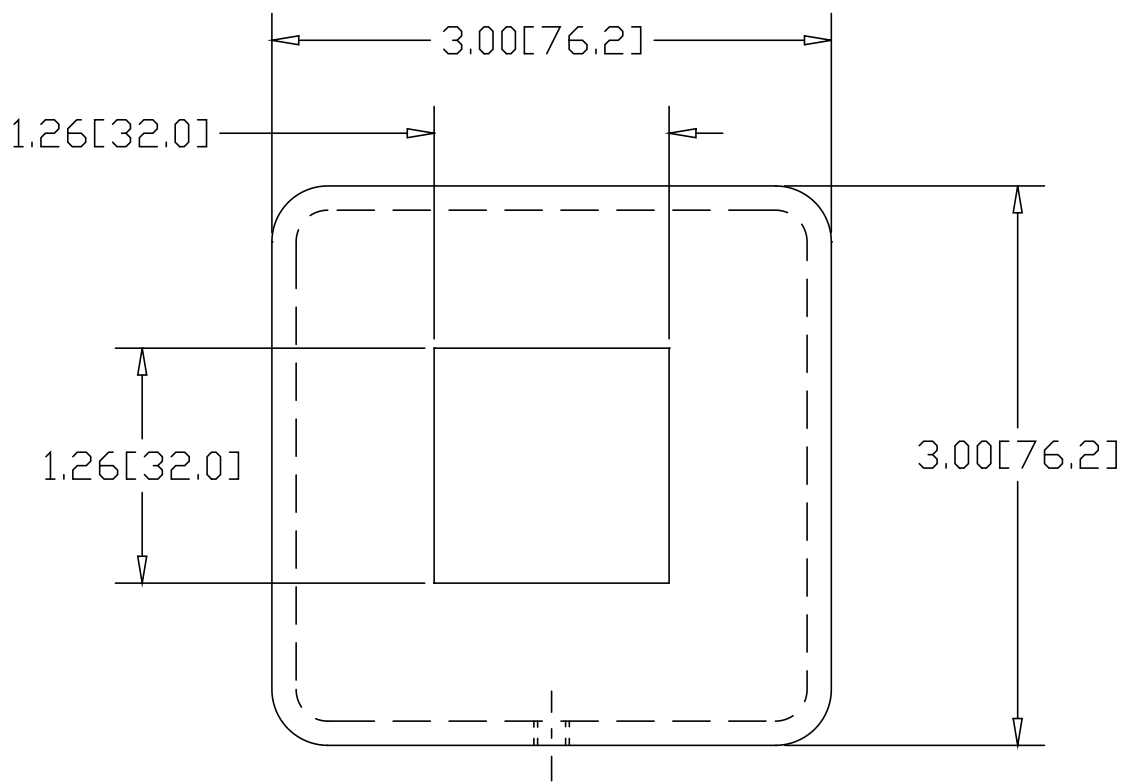

INCHES [MILLIMETERS]

ALTERNATE MATERIAL	PART NUMBER
.125 (3003) ALUMINUM ASTM B209	8788
10 GA. (304) STAINLESS STEEL ASTM A240	8858

PART NAME 1-1/4" SQUARE TUBE HFB FLANGE WITH SET-SCREW			
MATERIAL 10 GA. HRP&O STEEL ASTM A569			
DATE 6/20/95		R & B WAGNER, INC.	
DRAWN BY RJF		SIZE A	WEIGHT .42 LBS
FINISH MILL			REV