

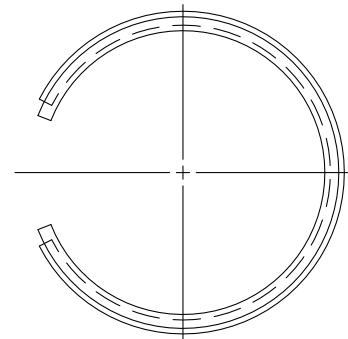

REV  
SH  
1023T  
DWG NO

REVISIONS			
REV	DESCRIPTION	DATE	APPROVED

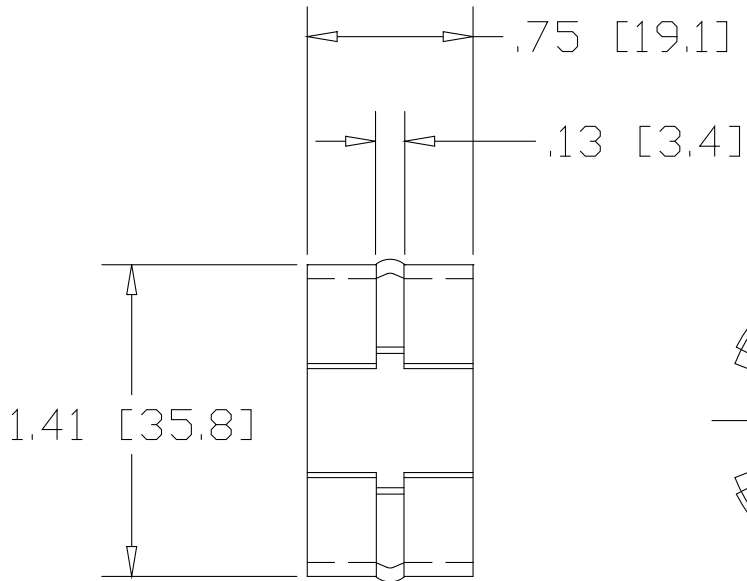
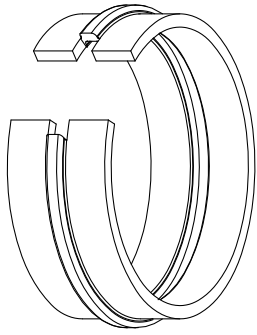

INCHES [MILLIMETERS]

ALTERNATE MATERIAL	PART NUMBER
.063 (3003) ALUMINUM ASTM B209	1024T
.0595 (304) STAINLESS STEEL ASTM A240	1025T

PART NAME 1.50" OD .065W TUBE WEDGE-LOCK WELDING CONNECTOR				
MATERIAL 16 GA. (.063) HRP&D STEEL ASTM A569				
DATE 10/10/01		<b>THE WAGNER COMPANIES</b> R & B WAGNER, INC. AND J. G. BRAUN CO.		
DRAWN BY JAH				
FINISH MILL	SIZE A	WEIGHT .05 LBS	PART NUMBER 1023T	REV