

REV
SH
8155B
DWG NO

REVISIONS			
REV	DESCRIPTION	DATE	APPROVED

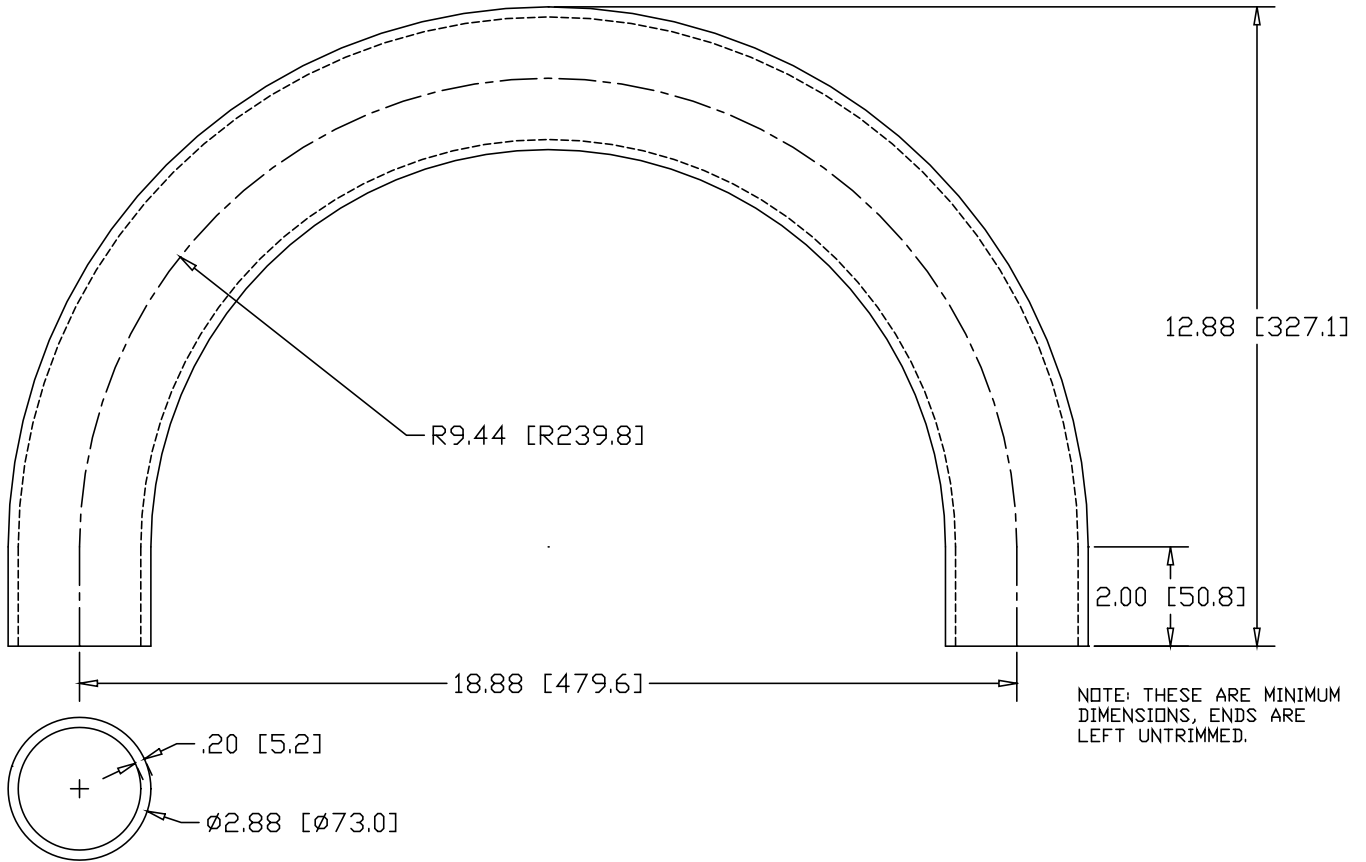

INCHES [MILLIMETERS]

ALTERNATE MATERIAL	PART NUMBER
2-1/2" SCH 40 (6063) ALUMINUM PIPE	8169B
2-1/2" SCH 40 (304) STAINLESS STEEL PIPE	8183B

PART NAME 2-1/2" PIPE SIZE 180° ELL X 8" I.R. W/ (2) 2" TANGENTS			
MATERIAL 2-1/2" SCH 40 A53 STEEL PIPE			
DATE 7/31/01	WAGNER	R & B WAGNER, INC.	
DRAWN BY JAH			
FINISH MILL			
SIZE A	WEIGHT 16.15 LBS	PART NUMBER 8155B	REV