

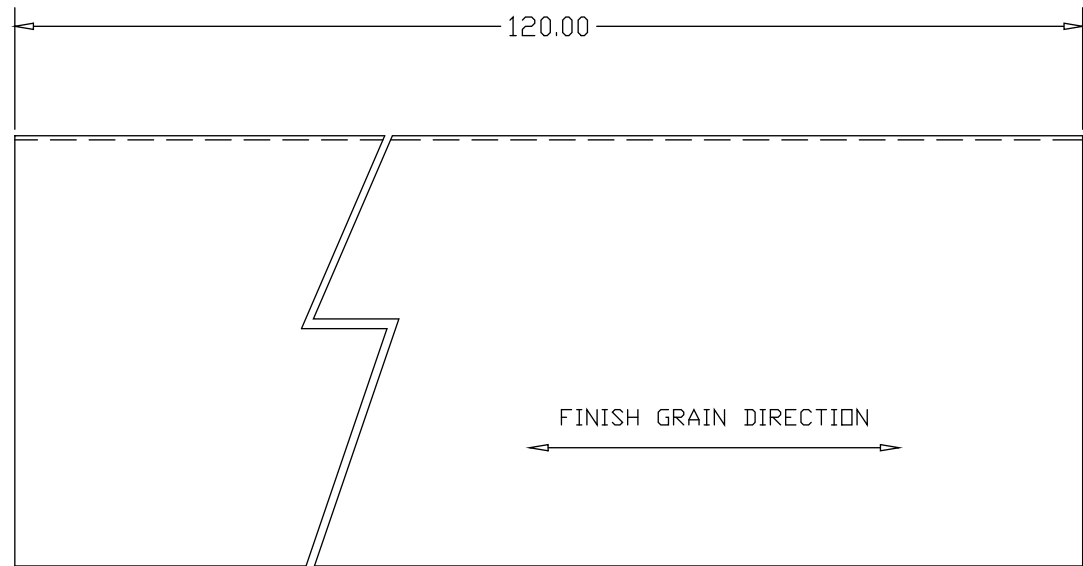

REVISIONS			
REV	DESCRIPTION	DATE	APPROVED
1	REVISED MAT'L THICKNESS, ALLOY	06/02/10	PWH
2	REVISED FLANGE TOLERANCES	10/29/10	RJF

#4 FINISH ON OUTSIDE
VINYL PROTECTED

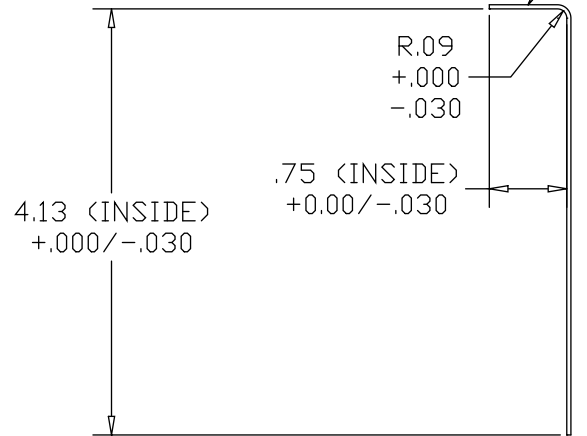

PART NAME		CLADDING, GLASS RAIL SHOE MOLDING		
MATERIAL		.063 5005 ALUMINUM		
DATE	11/18/09		THE WAGNER COMPANIES R & B WAGNER, INC. AND J. G. BRAUN CO.	
DRAWN BY	RDC			
FINISH	SATIN CLEAR ANODIZED	SIZE	WEIGHT	PART NUMBER
		A	2.90 LBS	GR2802.4AN
				REV 2