

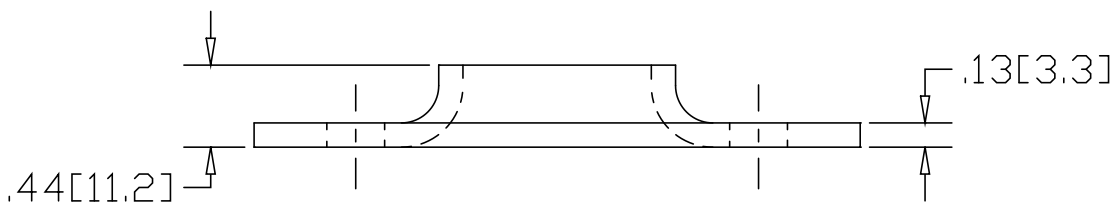

REV
SH
DWG NO 619AT

REVISIONS			
REV	DESCRIPTION	DATE	APPROVED

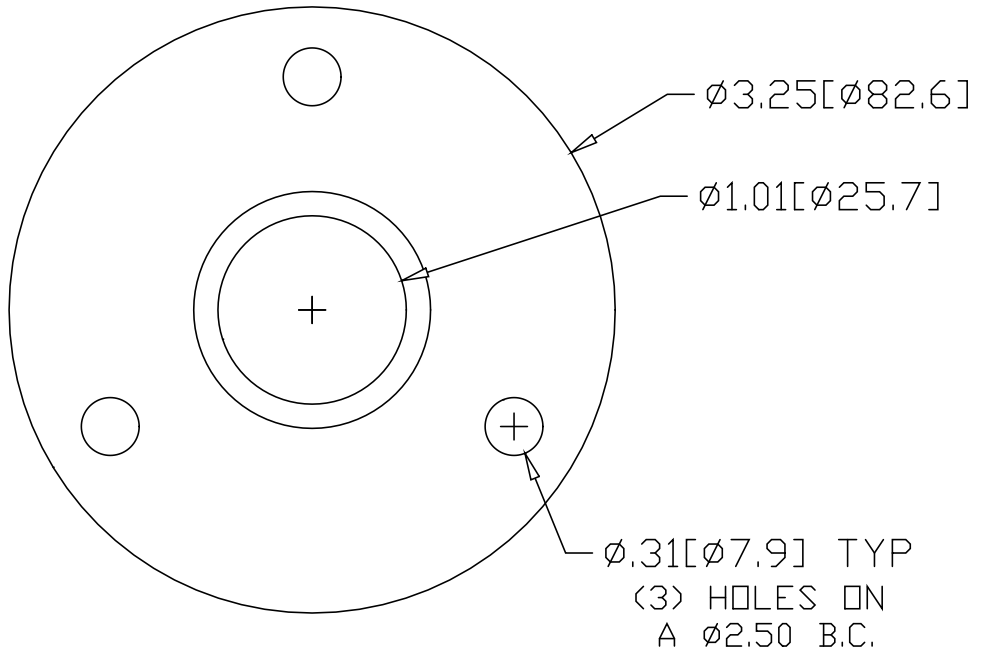

INCHES [MILLIMETERS]

ALTERNATE MATERIAL		PART NUMBER					
.125 (3003) ALUMINUM ASTM B209		659AT					
10 GA. (304) STAINLESS STEEL ASTM A240		699AT					
PART NAME 1" O.D. TUBE FLAT BASE FLANGE W/(3) HOLES							
MATERIAL 10 GA. HRP&O STEEL ASTM A-569							
DATE	1/11/99	 R & B WAGNER, INC.					
DRAWN BY	RJF						
FINISH	MILL						
SIZE	A	WEIGHT	.3 LBS	PART NUMBER	619AT	REV	