

REV B
SH
S101
DWG NO

REVISIONS			
REV	DESCRIPTION	DATE	APPROVED
A	Ø.38 WAS Ø.44 CENTER HOLE	07/25/05	RJF
B	RADIUS ADDED BOTH ENDS	02/15/06	RJF

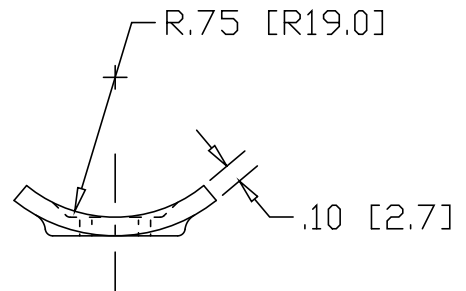
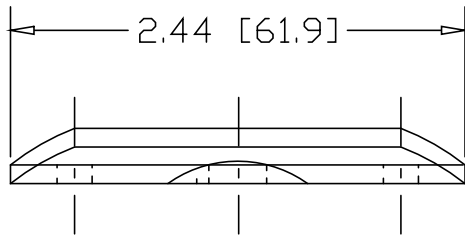
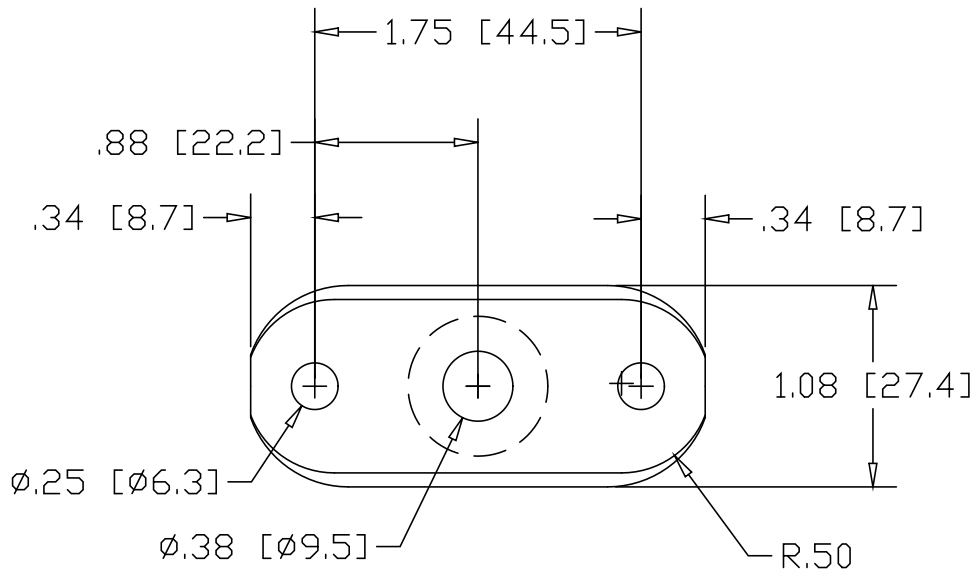

ALTERNATE MATERIAL	PART NUMBER
12 GA. 304 STAINLESS STEEL SHEET	S103
.125 (3003) ALUMINUM SHEET	S102
.125 (260) BRASS SHEET	S104
.125 (280) MUNTZ METAL	S105

PART NAME		HANDRAIL BRACKET SADDLE	
MATERIAL		12 GA. HRP&O STEEL SHEET	
DATE	1/20/06		THE WAGNER COMPANIES R & B WAGNER, INC. AND J. G. BRAUN CO.
DRAWN BY	RDC		
FINISH	MILL		
SIZE	A	WEIGHT	.07 LBS
PART NUMBER		S101	
REV		B	