

REV  
SH  
5640  
DWG NO

REVISIONS			
REV	DESCRIPTION	DATE	APPROVED

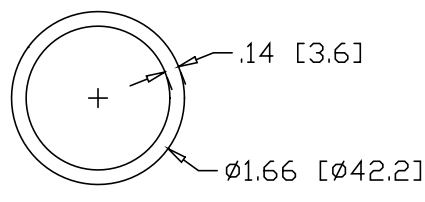
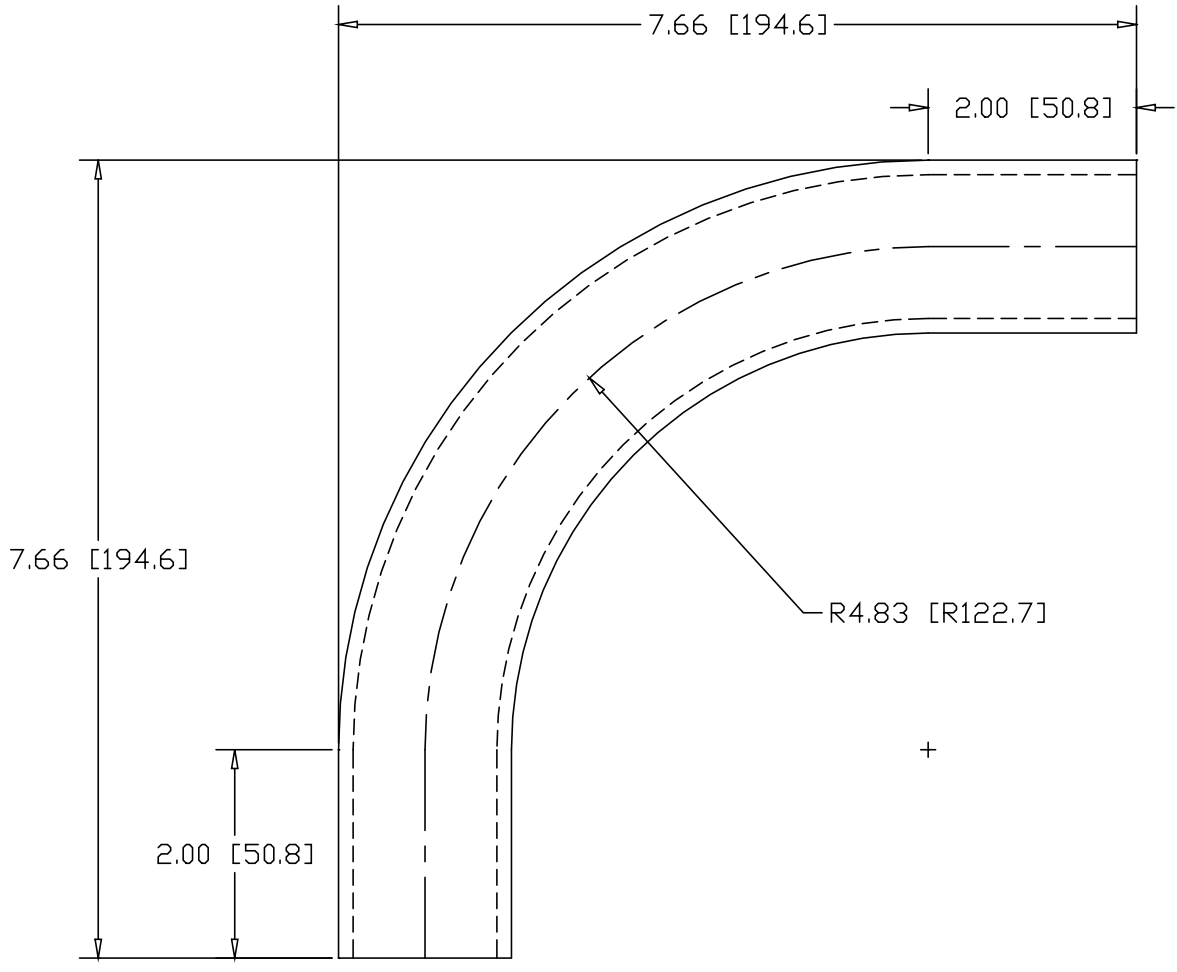

INCHES [MILLIMETERS]

ALTERNATE MATERIAL	PART NUMBER
1-1/4" SCH 40 (6063) ALUMINUM PIPE	5650
1-1/4" SCH 40 (304) STAINLESS STEEL PIPE	5656

PART NAME 1-1/4" PIPE SIZE 90° ELL X 4" I.R. W/ (2) 2" TANGENTS			
MATERIAL 1-1/4" SCH 40 A53 STEEL PIPE			
DATE 4/5/96	<b>WAGNER</b>	R & B WAGNER, INC.	
DRAWN BY RJF			
FINISH MILL			
SIZE A	WEIGHT 2.18 LBS	PART NUMBER 5640	REV