

REV
SH
7914
DWG NO

REVISIONS			
REV	DESCRIPTION	DATE	APPROVED

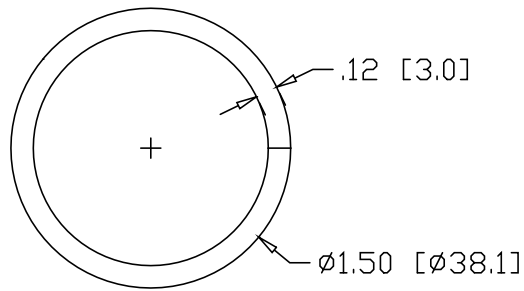
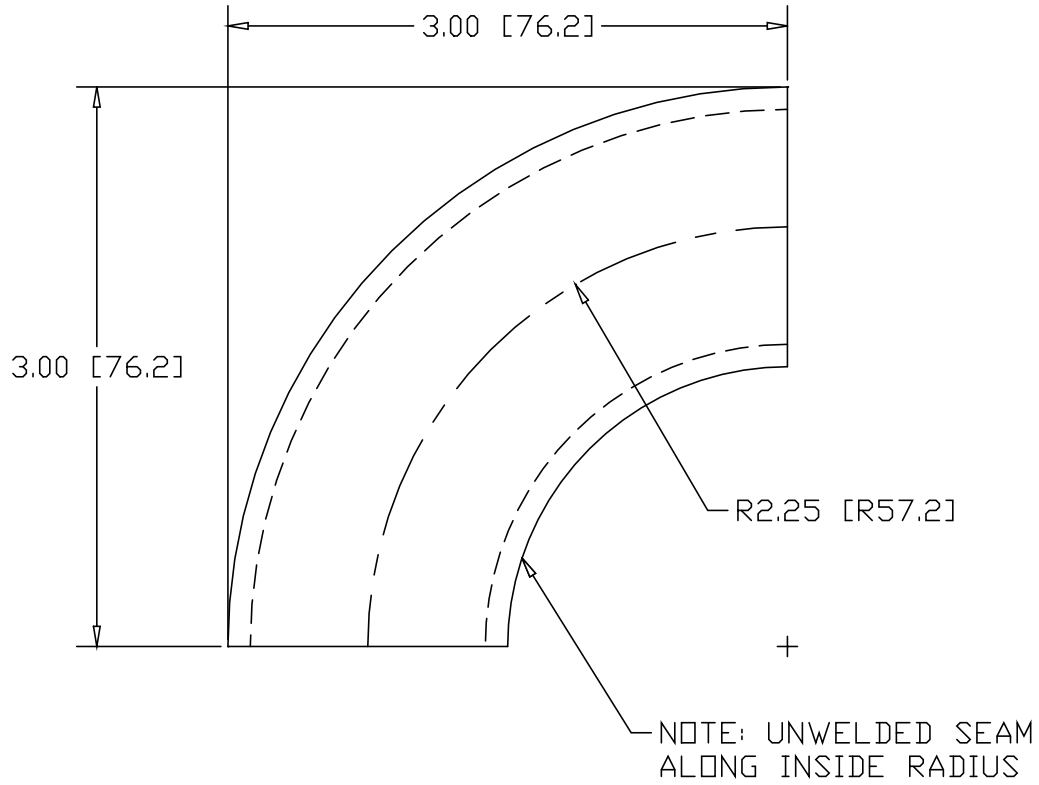

INCHES [MILLIMETERS]

ALTERNATE MATERIAL	PART NUMBER
.125 (3003) ALUMINUM ASTM B209	7930
11 GA. (304) STAINLESS STEEL ASTM A240	7946

PART NAME		1.50" OD TUBE 2.25" CLR 90° ELL					
MATERIAL		11 GA. HRP&D STEEL ASTM A569					
DATE	8/25/03						
DRAWN BY	RJF						
FINISH	MILL						
SIZE	A	WEIGHT	.45 LBS	PART NUMBER	7914	REV	